

1 Scope: This specification applies to Large current and Low Loss SMD Power INDUCTOR

2 Part Numbering: Product Identification

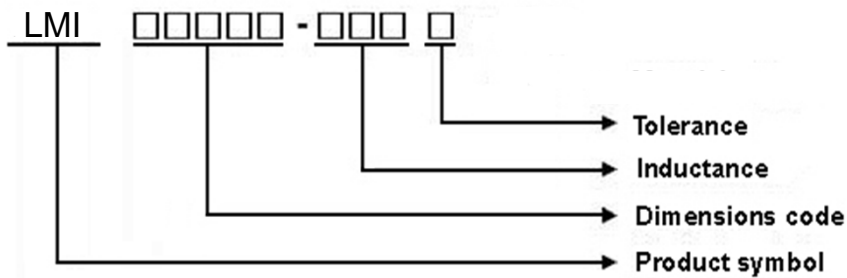

3 Rating:

Operating Temperature: - 5 5 °C ~ 1 2 5 °C (Including self - temperature rise)

Storage Temperature: Under 2 5 °C , Humidity < 75% RH

4 Marking:

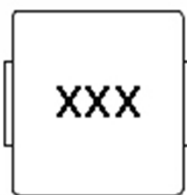

Ex : LMI05030-1R0M

Marking : 1R0

Marking color : Black

5 Standard Testing Condition

	Unless otherwise specified	In case of doubt
Temperature	Ordinary Temperature(15 to 35°C)	20±2°C
Humidity	Ordinary Humidity(25 to 85% RH)	60 to 70 % RH

6 Configuration and Dimensions:

Shape and Dimensions

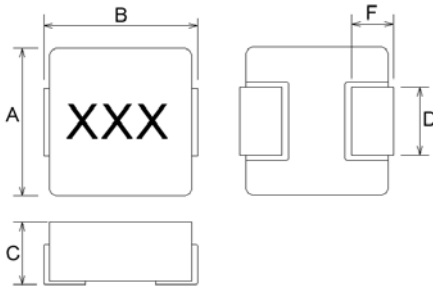

Dimensions in mm

TYPE	A	B Max	C Max	D	F
05030	5.4±0.35	5.7±0.2	3.0	2.0±0.3	1.5±0.3

7 ELECTRICAL CHARACTERISTICS :

Part No.	Inductance (uH)	Test Freq.	I _{rms} (A)Typ.	I _{sat} (A)Typ.	RDC (mΩ)Max.	Tolerance (±%)	Marking
LMI05030-R68M	0.68	100kHz,0.5V	8	14	12(11typ)	20	R68
LMI05030-1R0M	1	100kHz,0.5V	7	11	15(14typ)	20	1R0
LMI05030-1R2M	1.2	100kHz,0.5V	6.5	11	16(15typ)	20	1R2
LMI05030-1R5M	1.5	100kHz,0.5V	6	10	25(20typ)	20	1R5
LMI05030-2R2M	2.2	100kHz,0.5V	5	8	35(29typ)	20	2R2
LMI05030-3R3M	3.3	100kHz,0.5V	4.5	7	46(38typ)	20	3R3
LMI05030-4R7M	4.7	100kHz,0.5V	4	6	60(50typ)	20	4R7

NOTE:

1. **I_{rms}** DC current (A) that will cause an approximate ΔT of 40°C.
2. **I_{sat}** DC current (A) that will cause L_o to drop approximately 30%
3. Operating Temperature Range - 55°C to + 125°C
4. The part temperature (ambient + temp rise) should not exceed 125°C under worst case operating Circuit design 125°C under worst case operating conditions. component placement, PWB trace size and thickness, airflow and other cooling provisions all affect the part temperature. Part temperature should be verified in the end application.

8 LMI05030 Series

8.1 Construction:

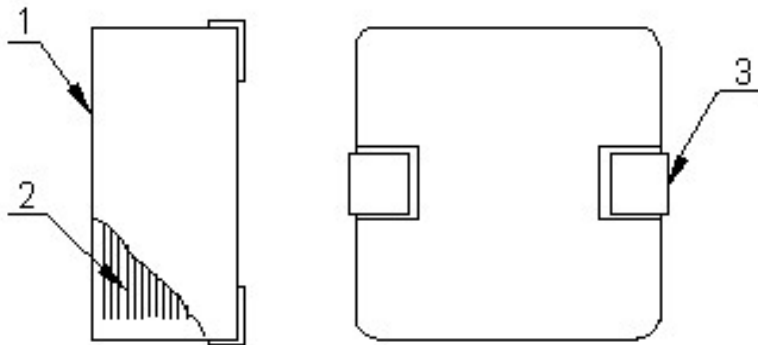

8.2 Material List:

ITEM	PART	DESCRIPTION
1	CORE	Alloy power
2	WIRE	Copper wire
3	TERMINAL	TERMINAL COPPER

9 Reliability Of Large Current and Low Loss SMD Power Inductor

1-1.Mechanical Performance

No	Item	Specification	Test Method
1-1-1	Vibration	Appearance: No damage Inductance: within $\pm 10\%$ of initial value	Test device shall be soldered on the substrate Oscillation Frequency: 10 to 55 to 10Hz for 1min Amplitude: 1.5mm Time: 2hrs for each axis (X, Y & Z), total 6hrs
1-1-2	Resistance to Soldering Heat	Appearance: No damage	Pre-heating: 150°C, 1min Solder Composition: Sn/Ag3.0/Cu0.5 Solder Temperature: 260 \pm 5°C Immersion Time: 10 \pm 1sec
1-1-3	Solder ability	The electrodes shall be at least 95% covered with new solder coating	Pre-heating: 150°C, 1min Solder Composition: Sn/Ag3.0/Cu0.5 Solder Temperature: 245 \pm 5°C Immersion Time: 4 \pm 1sec
1-1-4	Resistance to solvent	There must be no change in appearance or obliteration of marking.	Inductors must withstand 6 minutes of alcohol or water.

1-2.Environmental Performance

No	Item	Specification	Test Method														
1-2-1	Temperature Shock	Appearance: No damage Inductance: within $\pm 10\%$ of initial value	10 cycles (Air to Air) 1 cycles shall consist of: 30 minutes exposure to -55 °C 30 minutes exposure to 125 °C 15 seconds maximum transition between temperatures														
1-2-2	Temperature Cycle		One cycle: <table border="1"> <thead> <tr> <th>Step</th> <th>Temperature (°C)</th> <th>Time (min)</th> </tr> </thead> <tbody> <tr> <td>1</td> <td>-55\pm3</td> <td>30</td> </tr> <tr> <td>2</td> <td>25\pm2</td> <td>3</td> </tr> <tr> <td>3</td> <td>125\pm3</td> <td>30</td> </tr> <tr> <td>4</td> <td>25\pm2</td> <td>3</td> </tr> </tbody> </table>	Step	Temperature (°C)	Time (min)	1	-55 \pm 3	30	2	25 \pm 2	3	3	125 \pm 3	30	4	25 \pm 2
Step	Temperature (°C)	Time (min)															
1	-55 \pm 3	30															
2	25 \pm 2	3															
3	125 \pm 3	30															
4	25 \pm 2	3															
1-2-3	Humidity Resistance		Total: 100cycles Measured after exposure in the room condition for 24hrs Temperature: 40 \pm 2°C Relative Humidity: 90 ~ 95% Time: 1000hrs Measured after exposure in the room condition for 24hrs														
1-2-4	Heat Life		Temperature: 85 \pm 3°C Relative Humidity: 20% Applied Current: Rated Current Time: 1000hrs Measured after exposure in the room condition for 24hrs														
1-2-5	Cold Resistance		Temperature: -55 \pm 3°C Relative Humidity: 0% Time: 1000hrs Measured after exposure in the room condition for 24hrs														

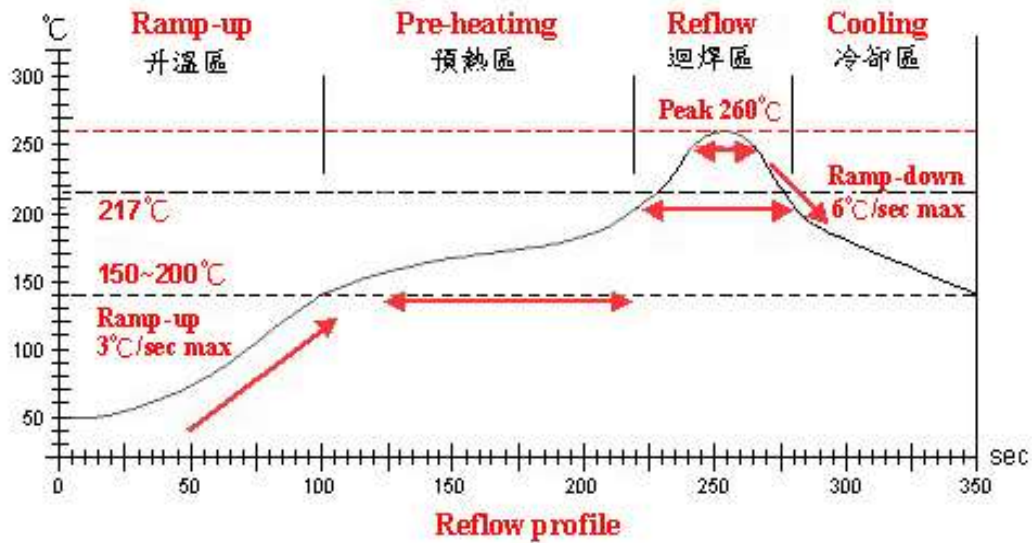

Lead-Free(LF) 標準溫度分析範圍

Refer to J-STD-020C

管制項目 Item.	升温區 Ramp-up	预热區 Pre-heating	迴焊區 Reflow	Peak Temp	冷却區 Cooling
溫度範圍 Temp. scope	R.T. ~ 150°C	150°C ~ 200°C	217°C	260±5°C	Peak Temp. ~ 150°C
標準時間 Time spec.	—	60 ~ 180 sec	60 ~ 150 sec	20 ~ 40 sec	—
實際時間 Time result	—	75 ~ 100 sec	90 ~ 120 sec	20 ~ 35 sec	—

10 PACKAGING

10.1 Packaging -Cover tape

The force for tearing off cover tape is 10 to 130 grams in the arrow direction.

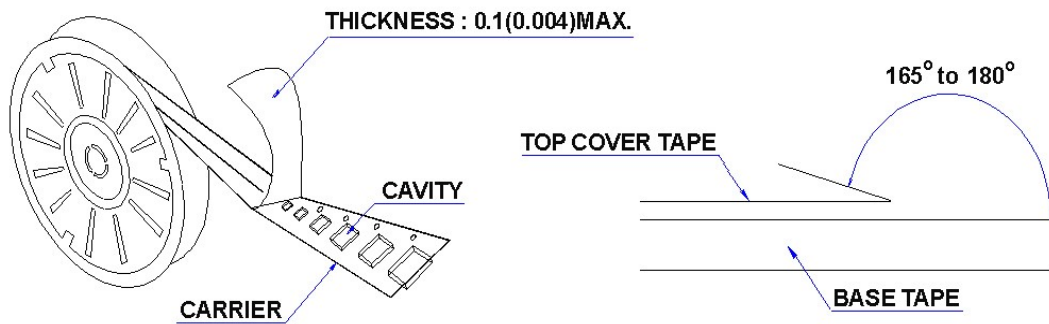

10.2 Packaging Quantity

TYPE	BULK	PCS/REEL
05030	✓	1000

10.3 Reel Dimensions

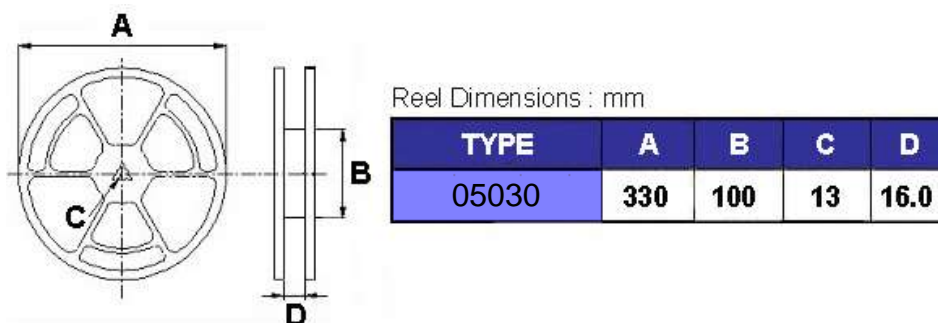

11 PACKAGING

11.4 Tape Dimensions in mm

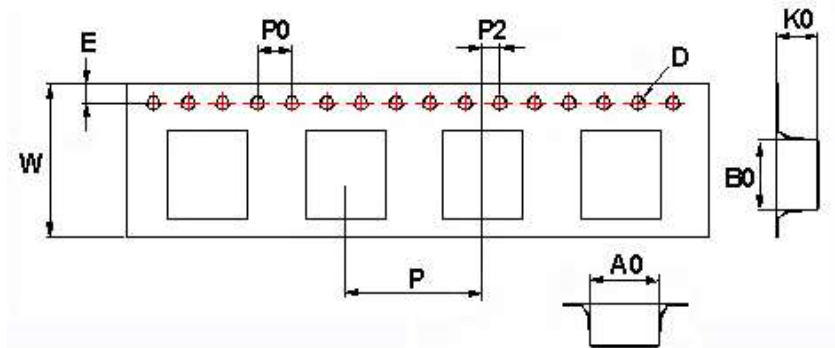

TYPE	A0	B0	K0	D	E	W	P	P0	P2
05030	5.9	6.2	3.4	1.55	1.75	16	12	4	2

12 Recommended Pattern

PAD LAYOUT

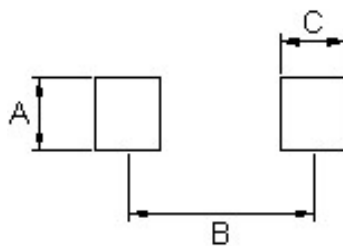

Dimensions in mm

TYPE	A(in/mm)	B(in/mm)	C(in/mm)
05030	0.098/2.5	0.161/4.1	0.075/1.9

13 Note:

1. Please make sure that your product is has been evaluated and confirmed against your specifications when our product is mounted to your product.
2. Do not knock nor drop.
3. All the items and parameters in this product specification have been prescribed on the premise that our product is used for the purpose, under the condition and in the environment agreed upon between you and us. You are requested not to use our product deviating from such agreement.
4. Please keep the distance between transformer/coil and other components (refer to the standard IEC 950)