

General Description

These N-Channel enhancement mode power field effect transistors are using trench DMOS technology. This advanced technology has been especially tailored to minimize on-state resistance, provide superior switching performance, and withstand high energy pulse in the avalanche and commutation mode. These devices are well suited for high efficiency fast switching applications.

General Features

$V_{DS} = 100V$ $I_D = 15A$

$R_{DS(ON)} < 110m\ \Omega$ @ $V_{GS} = 10V$

Inner Equivalent Principium Chart

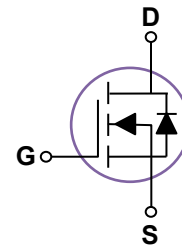

Pin Assignment

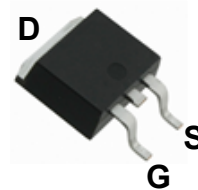

Package Marking and Ordering Information

Marking	Part Number	Package	Packing	Qty.
10110	LMAK15N10	TO-252	Reel	2500Pcs

Absolute Maximum Ratings $T_A = 25^\circ C$ unless otherwise noted

Parameter	Symbol	Maximum	Units
Drain-Source Voltage	V_{DS}	100	V
Gate-Source Voltage	V_{GS}	± 20	V
Drain Current-Continuous	TC=25°C	I_D	15
	TC=100°C	I_D	10.5
Drain Current – Pulsed	I_{DM}	60	A
Maximum Power Dissipation	P_D	34	W
Single pulse avalanche energy ⁽¹⁾	E_{AS}	9	mJ
Junction and Storage Temperature Range	T_J, T_{STG}	-55 To 150	°C

Thermal Characteristics

Parameter	Symbol	Typ	Max	Unit
Thermal Resistance junction-case	$R_{\theta JC}$		2.5	°C /W
Thermal Resistance unction-to-Ambient	$R_{\theta JA}$		62	°C /W

Electrical Characteristics (T_J=25°C unless otherwise noted)

Symbol	Parameter	Condition	Min	Typ	Max	Unit
STATIC PARAMETERS						
BV _{DSS}	Drain-Source Breakdown Voltage	V _{GS} =0V, I _D =250μA	100			V
I _{DSS}	Zero Gate Voltage Drain Current	V _{DS} =100V, V _{GS} =0V			1	μA
I _{GSS}	Gate-Body Leakage Current	V _{GS} =±20V, V _{DS} =0V			±100	nA
V _{GS(th)}	Gate Threshold Voltage	V _{DS} =V _{GS} , I _D =250μA	1.2	1.6	2.5	V
R _{DS(ON)}	Drain-Source On-State Resistance	V _{GS} =10V, I _D =10A		80	110	mΩ
		V _{GS} =4.5V, I _D =8A		90	125	mΩ
DYNAMIC PARAMETERS						
C _{iss}	Input Capacitance	V _{DS} =25V, V _{GS} =0V, F=1.0MHz		1200		pF
C _{oss}	Output Capacitance			60		pF
C _{rss}	Reverse Transfer Capacitance			35		pF
SWITCHING PARAMETERS						
t _{d(on)}	Turn-on Delay Time	V _{DD} =50V, I _D =1A, V _{GS} =10V, R _G =6Ω		18		nS
t _r	Turn-on Rise Time			4		nS
t _{d(off)}	Turn-Off Delay Time			40		nS
t _f	Turn-Off Fall Time			3		nS
Q _g	Total Gate Charge	V _{DS} =50V, I _D =2A, V _{GS} =10V		20		nC
Q _{gs}	Gate-Source Charge			3.2		nC
Q _{gd}	Gate-Drain Charge			3.6		nC
R _g	Gate resistance	V _{GS} =0V, V _{DS} =0V, F=1MHz		2		Ω
V _{SD}	Diode Forward Voltage	V _{GS} =0V, I _{SD} =1A		0.7	1.2	V

Note:

1. Repetitive Rating : Pulsed width limited by maximum junction temperature.
2. V_{DD}=50V, V_{GS}=10V, L=0.1mH, I_{AS}=12A., Starting T_J=25°C
3. The data tested by pulsed , pulse width ≅ 300us , duty cycle ≅ 2%.
4. Essentially independent of operating temperature.

TYPICAL ELECTRICAL AND THERMAL CHARACTERISTICS

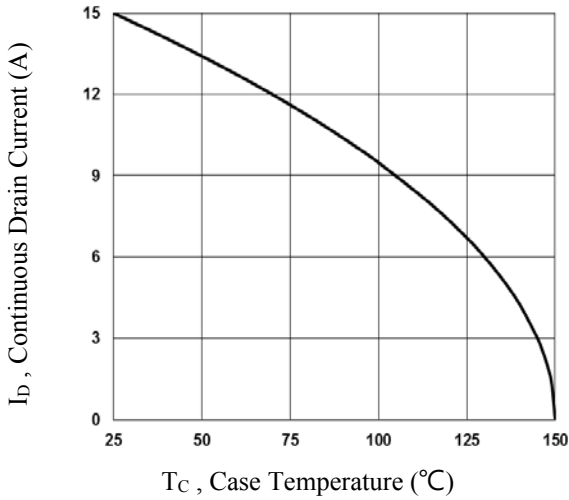

Fig.1 Continuous Drain Current vs. T_c

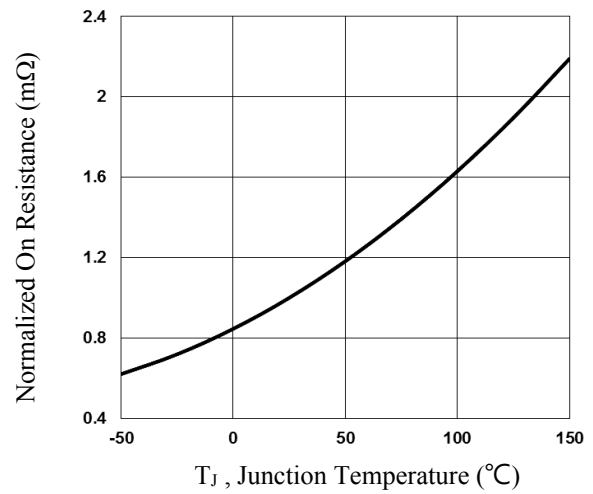

Fig.2 Normalized R_{DS(on)} vs. T_j

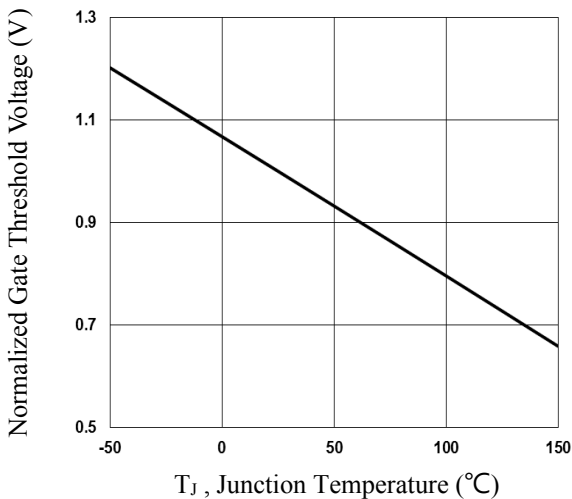

Fig.3 Normalized V_{th} vs. T_j

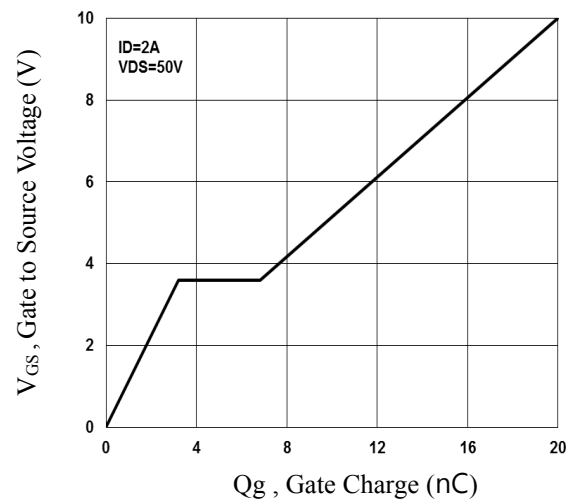

Fig.4 Gate Charge Waveform

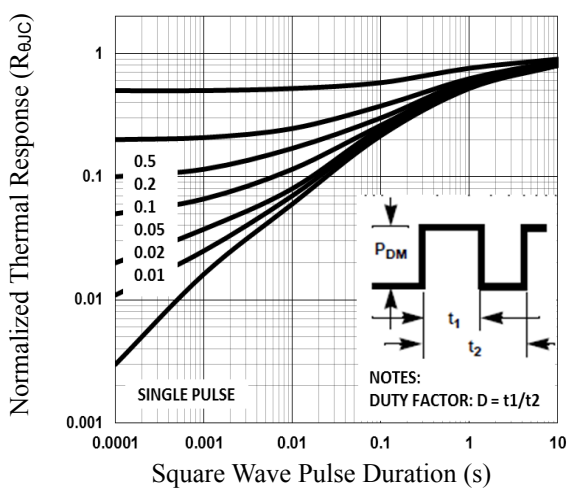

Fig.5 Normalized Transient Impedance

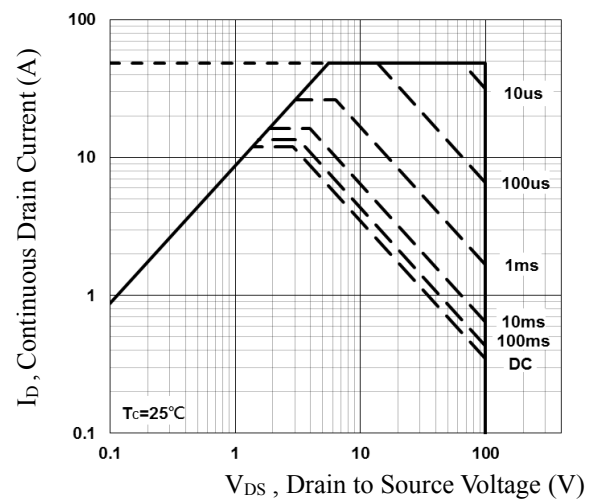

Fig.6 Maximum Safe Operation Area

TYPICAL ELECTRICAL AND THERMAL CHARACTERISTICS

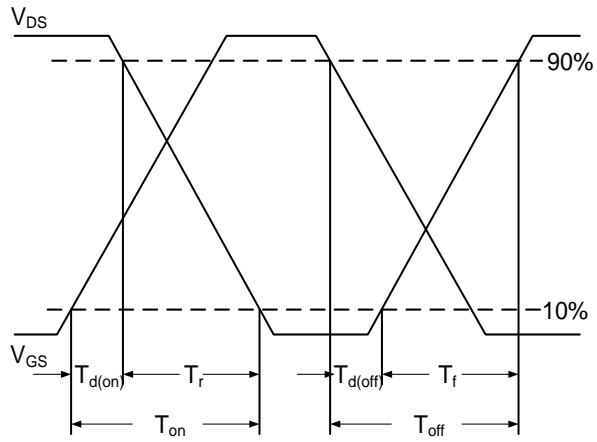

Fig.7 Switching Time Waveform

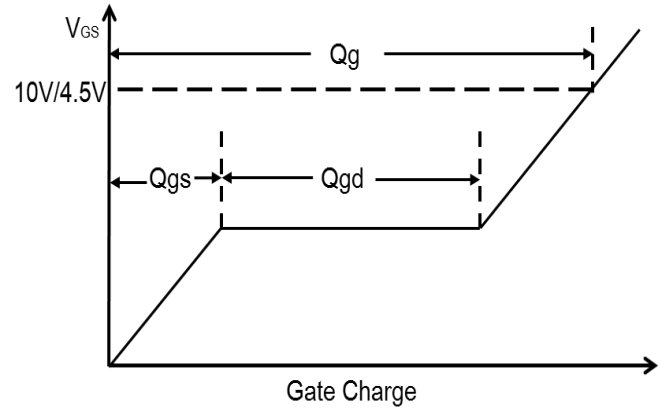
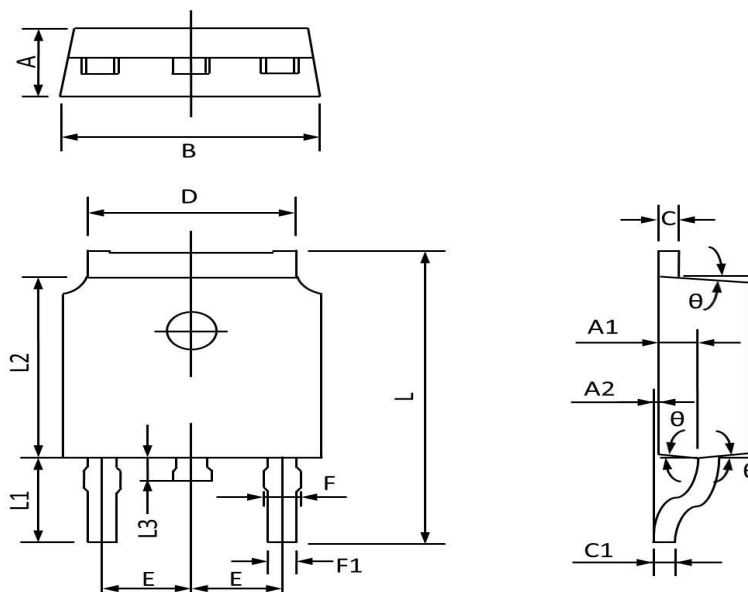

Fig.8 Gate Charge Waveform

Package Outline



Symbol	Dimensions In Millimeters		Dimensions In Inches	
	MAX	MIN	MAX	MIN
A	2.400	2.200	0.094	0.087
A1	1.110	0.910	0.044	0.036
A2	0.150	0.000	0.006	0.000
B	6.800	6.400	0.268	0.252
C	0.580	0.450	0.023	0.018
C1	0.580	0.460	0.023	0.018
D	5.500	5.100	0.217	0.201
E	2.386	2.186	0.094	0.086
F	1.140	0.600	0.045	0.024
F1	0.880	0.500	0.035	0.020
L	10.400	9.400	0.409	0.370
L1	3.000	2.400	0.118	0.094
L2	6.223	5.400	0.245	0.213
L3	1.200	0.600	0.047	0.024
θ	9°	3°	9°	3°

NOTICE

Leiditech reserves the right to make modifications, enhancements, improvements, corrections or other changes without further notice to any product herein. Leiditech does not assume any liability arising out of the application or use of any product described herein.

Shanghai Leiditech Electronic Co., Ltd
 Email: sale1@leiditech.com
 Tel : +86- 021 50828806
 Fax : +86- 021 50477059