

Positive Thermal Coefficient Diodes

SMD2018P030~200 Series

The SMD2018 Series PTC provides surface mount overcurrent protection for applications where space is at a premium and resettable protection is desired.

Features

- RoHS compliant, lead-free and halogen-free
- Fast response to fault currents
- Compact design saves board space
- Low resistance
- Low-profile
- Compatible with high temperature solders

Applications

- USB peripherals
- Disk drives
- CD-ROMs
- Plug and play protection for motherboards and peripherals
- Mobile phones - battery and port protection
- Disk drives
- PDAs / digital cameras
- Game console port protection



Dimension

MARKING CODE VARIES WITH AMPERAGE RATING (See Electrical Characteristic Table) SHOWN IS 1.0AMP RATING

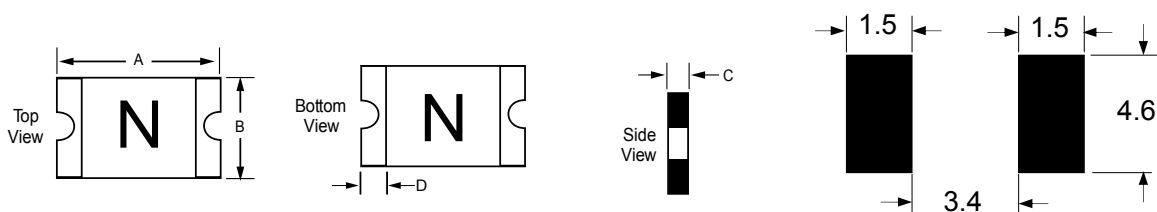

Model	A		B		C		D
	Min.	Max.	Min.	Max.	Min.	Max.	Min.
SMD2018P030TF	4.72	5.44	4.22	4.93	0.60	1.10	0.30
SMD2018P050TF	4.72	5.44	4.22	4.93	0.60	1.10	0.30
SMD2018P100TF	4.72	5.44	4.22	4.93	0.45	0.80	0.30
SMD2018P100TF/33	4.72	5.44	4.22	4.93	0.45	0.80	0.30
SMD2018P150TF	4.72	5.44	4.22	4.93	0.45	0.80	0.30
SMD2018P200TF	4.72	5.44	4.22	4.93	0.40	0.80	0.30

Electrical Characteristics

Type Number	I_{hold}	I_{trip}	V_{max}	I_{max}	P_d max.	Maximum Time To Trip		Resistance	
	(A)	(A)	$V_{(dc)}$	(A)	(W)	Current (A)	Time (Sec.)	R_{min} (Ω)	R_{1max} (Ω)
SMD2018P030TF	0.30	0.60	60	100	0.9	1.5	3.0	0.50	2.30
SMD2018P050TF	0.55	1.20	60	100	1.0	2.5	3.0	0.20	1.00
SMD2018P100TF	1.10	2.20	15	100	1.1	8.0	0.4	0.06	0.36
SMD2018P100TF/33	1.10	2.20	33	100	1.1	8.0	0.4	0.06	0.36
SMD2018P150TF	1.50	3.00	15	100	1.1	8.0	0.8	0.05	0.17
SMD2018P200TF	2.00	4.20	10	100	1.1	8.0	2.4	0.03	0.10

I_{hold} = Hold current: maximum current device will pass without tripping in 20°C still air.

I_{trip} = Trip current: minimum current at which the device will trip in 20°C still air.

V_{max} = Maximum voltage device can withstand without damage at rated current (I_{max})

I_{max} = Maximum fault current device can withstand without damage at rated voltage (V_{max})

P_d = Power dissipated from device when in the tripped state at 20°C still air.

R_{min} = Minimum resistance of device in initial (un-soldered) state.

Thermal Derating Chart-IH(A)

Model	Maximum ambient operating temperature (T_{mao}) vs. hold current (I_{hold})								
	-40°C	-20°C	0°C	25°C	40°C	50°C	60°C	70°C	85°C
SMD2018P030TF	0.48	0.42	0.35	0.30	0.24	0.21	0.17	0.15	0.10
SMD2018P050TF	0.87	0.77	0.67	0.55	0.46	0.41	0.36	0.31	0.23
SMD2018P100TF	1.71	1.52	1.32	1.10	0.94	0.84	0.74	0.64	0.50
SMD2018P100TF/33	1.71	1.52	1.32	1.10	0.94	0.84	0.74	0.64	0.50
SMD2018P150TF	2.38	2.10	1.82	1.50	1.27	1.13	0.99	0.85	0.64
SMD2018P200TF	2.95	2.65	2.35	2.00	1.74	1.59	1.44	1.29	1.06

Thermal Derating Curve

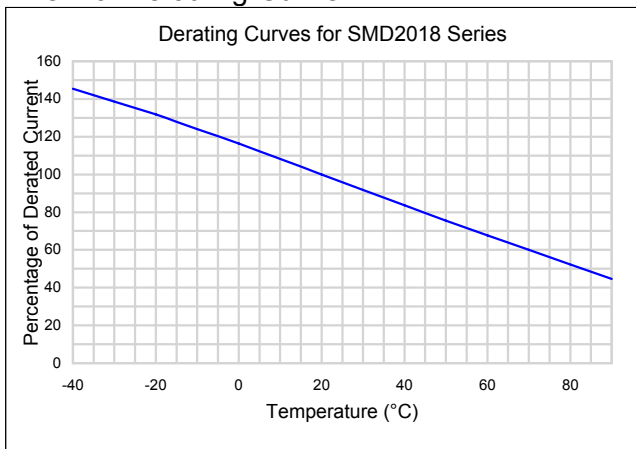

Typical Time-To-Trip At 25°C

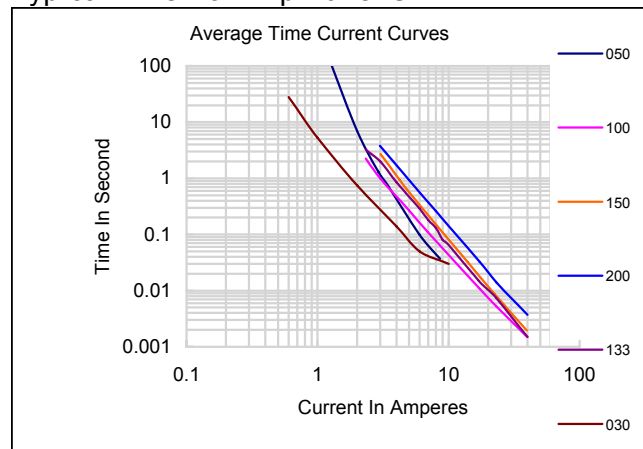

Recommended Solder Reflow Conditions

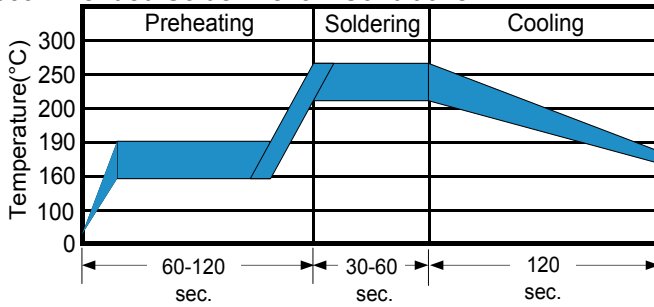

- Recommended reflow methods: IR, vapor phase oven, hot air oven.
 - Devices are not designed to be wave soldered to the bottom side of the board.
 - Recommended maximum paste thickness is 0.25 mm (0.010 inch).
 - Devices can be cleaned using standard method and solvents.
- Note: If reflow temperatures exceed the recommended profile, devices may not meet the performance requirements.

Tape And Reel Specifications (mm)

Governing Specifications	EIA 481-2
W	12.0 ± 0.20
P ₀	4.0 ± 0.10
P ₁	8.0 ± 0.10
P ₂	2.0 ± 0.05
A ₀	4.40 ± 0.10
B ₀	5.50 ± 0.10
B _{1max.}	8.2
D ₀	1.5 + 0.1, -0.0
F	5.5 ± 0.05
E ₁	1.75 ± 0.10
E _{2min.}	10.25
Tmax.	0.6
T _{1max.}	0.1
K ₀	1.36 ± 0.1
Leader min.	390
Trailer min.	160
Reel Dimensions	
A max.	178
N min.	50
W ₁	12.4 + 2.0, -0.0
W _{2max.}	18.4

EIA Tape Component Dimensions

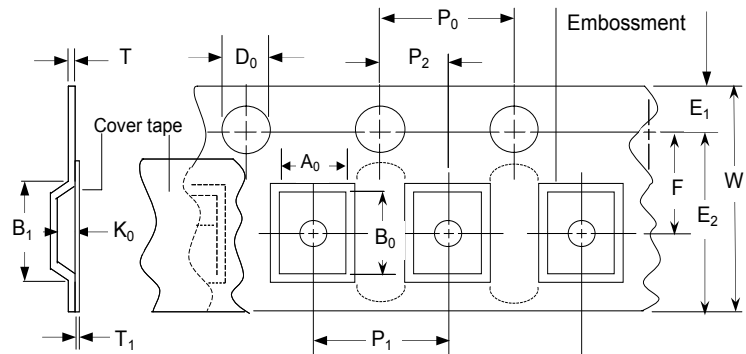

EIA Reel Dimensions

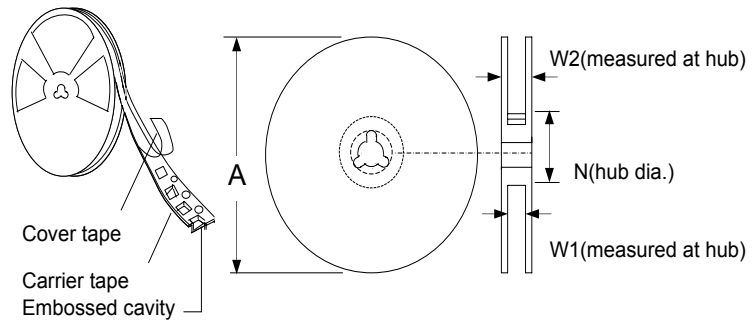

Storage And Handling

- Storage conditions : 40°C max, 70% R.H.
- Devices may not meet specified performance if storage conditions are exceeded.

Order Information

SMD2018	050
Product name	Hold
Size 5045 mm / 2018 mils	Current
SMD : surface mount device	0.50A

Packaging

Tape & Reel Quantity	
030, 050	1,500 pcs/reel
100, 100-33V, 150, 200	2,500 pcs/reel

Tape & reel packaging per EIA481-1

Leiditech Electronics are trademarks.

Information furnished is believed to be accurate and reliable. However, users should independently evaluate the suitability of and test each product selected for their own applications. Leiditech Electronics reserves the right to change or update, without notice, any information contained in this publication; to change, without notice, the design, construction, processing, or specification of any product; and to discontinue or limit production or distribution of any product. This publication supersedes and replaces all information previously supplied. Without expressed or written consent by an officer of Leiditech Electronics, Leiditech Electronics does not authorize the use of any of its products as components in nuclear facility applications, aerospace, or in critical life support devices or systems. Leiditech Electronics expressly disclaims all implied warranties regarding the information contained herein, including, but not limited to, any implied warranties of merchantability or fitness for a particular purpose. Leiditech Electronics' only obligations are those in the Leiditech Electronics Standard Terms and Conditions of Sale and in no case will Leiditech Electronics be liable for any incidental, indirect, or consequential damages.

SHANGHAI LEIDITECH ELECTRONICS CO.,LTD

Tel: +86- 021 50828806

Fax: +86- 021 50477059-8008

Email: sale1@leiditech.com

Website: <http://www.leiditech.com>