

Description

The LM5D90P03 uses advanced trench technology to provide excellent $R_{DS(ON)}$, low gate charge and operation with gate voltages as low as 4.5V. This device is suitable for use as a Battery protection or in other Switching application.

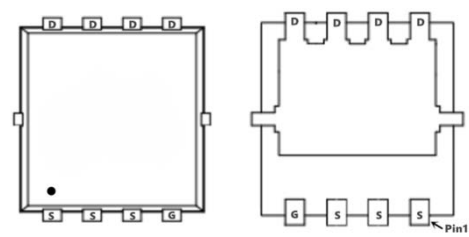
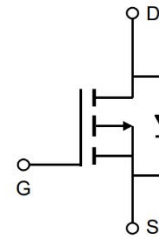

General Features

$V_{DS} = -30V$ $I_D = -90A$

$R_{DS(ON)} < 6.5m\Omega$ @ $V_{GS} = -10V$ (Typ. 4.9m Ω)

Application

- Lithium battery protection
- Wireless impact
- Mobile phone fast charging



Package Marking and Ordering Information

Device	Device Marking	Device Package	Reel Size	Tape width	Quantity
LM5D90P03	AP90P03NF	DFN5X6-8	-	-	5000 units

Absolute Maximum Ratings ($T_C = 25^\circ C$ unless otherwise noted)

Symbol	Parameter	Max.	Units
VDSS	Drain-Source Voltage	-30	V
VGSS	Gate-Source Voltage	± 20	V
ID	Continuous Drain Current $T_C = 25^\circ C$	-90	A
ID	Continuous Drain Current $T_C = 100^\circ C$	-59	A
IDM	Pulsed Drain Current ^{note1}	-360	A
EAS	Single Pulsed Avalanche Energy ^{note2}	210	mJ
PD	Power Dissipation $T_C = 25^\circ C$	109	W
R θ JC	Thermal Resistance, Junction to Case	1.4	$^\circ C/W$
TJ, TSTG	Operating and Storage Temperature Range	-55 to +175	$^\circ C$

Electrical Characteristics (T_J=25°C, unless otherwise noted)

Symbol	Parameter	Test Condition	Min.	Typ.	Max.	Units
V(BR)DSS	Drain-Source Breakdown Voltage	VGS=0V, ID= -250μA	-30	-33	-	V
IDSS	Zero Gate Voltage Drain Current	VDS= -30V, VGS=0V,	-	-	-1	μA
IGSS	Gate to Body Leakage Current	VDS=0V, VGS= ±20V	-	-	±100	nA
VGS(th)	Gate Threshold Voltage	VDS=VGS, ID= -250μA	-1.0	-1.6	-2.5	V
RDS(on)	Static Drain-Source on-Resistance	VGS= -10V, ID= -30A	-	4.9	6.4	mΩ
		VGS= -4.5V, ID= -20A	-	7.5	10.5	
Ciss	Input Capacitance	VDS= -15V, VGS=0V, f=1.0MHz	-	6800	-	pF
Coss	Output Capacitance		-	769	-	pF
Crss	Reverse Transfer Capacitance		-	726	-	pF
Qg	Total Gate Charge	VDS= -15V, ID= -30A, VGS= -10V	-	30	-	nC
Qgs	Gate-Source Charge		-	6	-	nC
Qgd	Gate-Drain("Miller") Charge		-	8	-	nC
td(on)	Turn-on Delay Time	VDD= -15V, ID= -30A, VGS= -10V, RGEN=2.5Ω	-	11	-	ns
tr	Turn-on Rise Time		-	13	-	ns
td(off)	Turn-off Delay Time		-	52	-	ns
tf	Turn-off Fall Time		-	21	-	ns
IS	Maximum Continuous Drain to Source Diode Forward Current		-	-	-90	A
ISM	Maximum Pulsed Drain to Source Diode Forward Current		-	-	-360	A
VSD	Drain to Source Diode Forward Voltage	VGS=0V, IS= -30 A		-0.8	-1.2	V

Notes:

- 1、Repetitive Rating: Pulse Width Limited by Maximum Junction Temperature
- 2、E AS condition: T_J =25°C, V_{DD} = -15V, V_G = -10V, R_G =25Ω, L=0.5mH, I_{AS} = -29A
- 3、Pulse Test: Pulse Width≤300μs, Duty Cycle≤2%

Typical Electrical and Thermal Characteristics

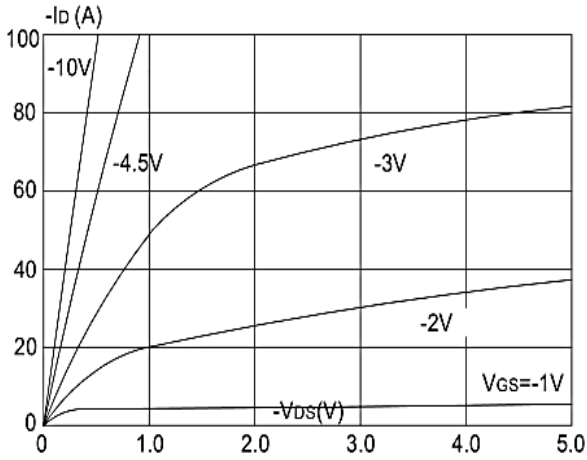

Figure 1: Output Characteristics

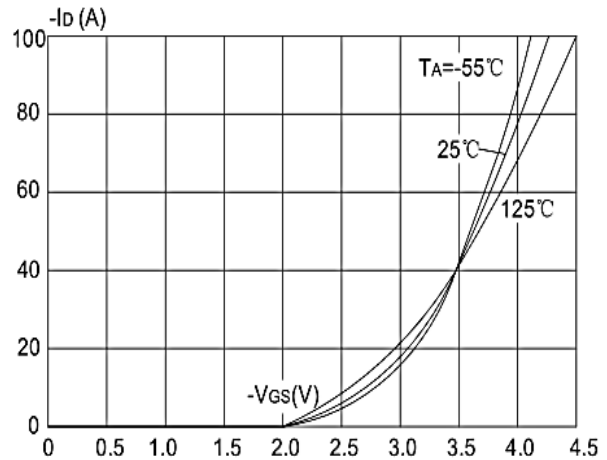

Figure 2: Typical Transfer Characteristics

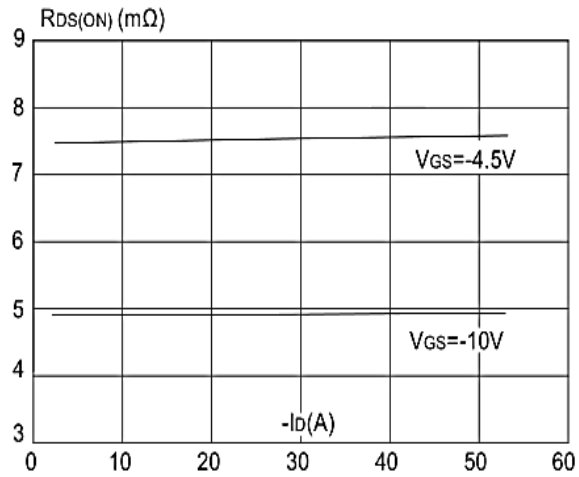

Figure 3: On-resistance vs. Drain Current

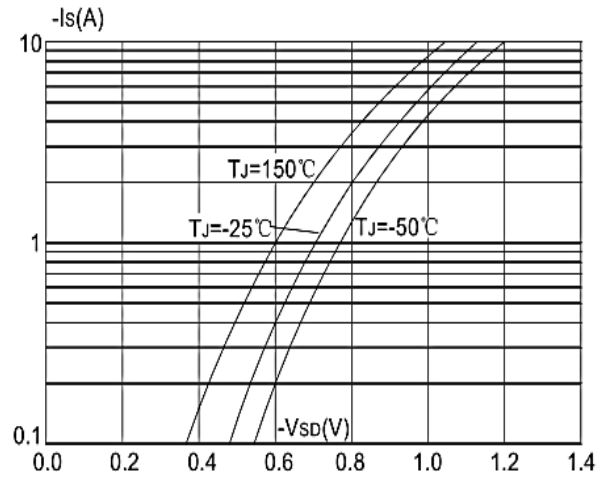

Figure 4: Body Diode Characteristics

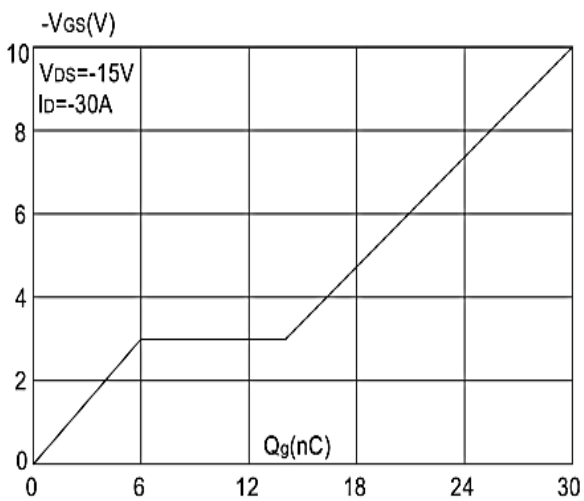

Figure 5: Gate Charge Characteristics

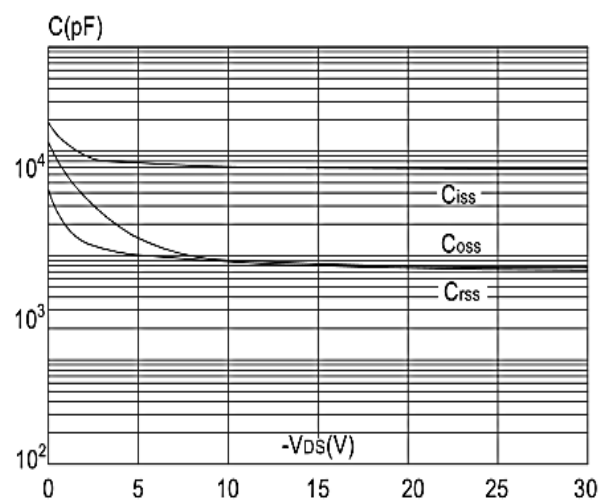

Figure 6: Capacitance Characteristics

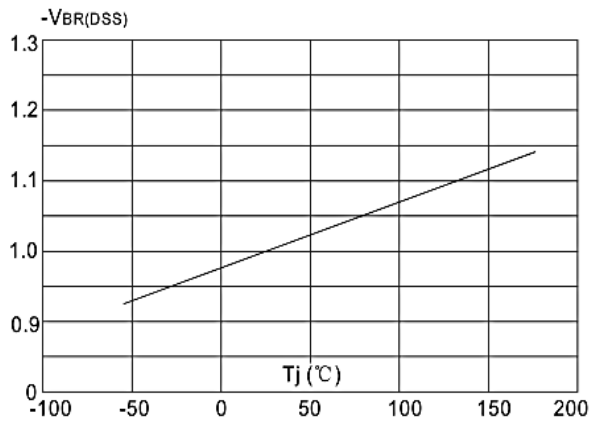

Figure 7: Normalized Breakdown Voltage vs. Junction Temperature

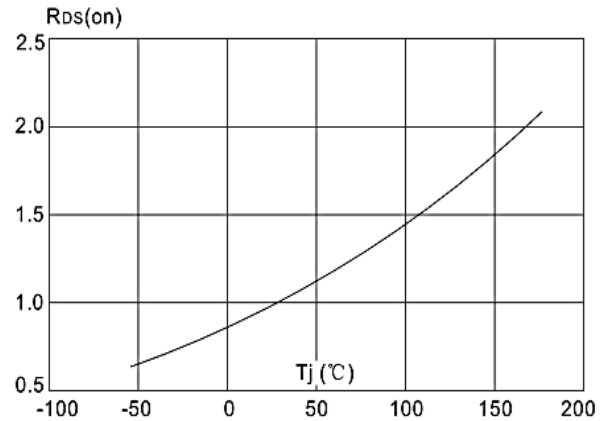

Figure 8: Normalized on Resistance vs. Junction Temperature

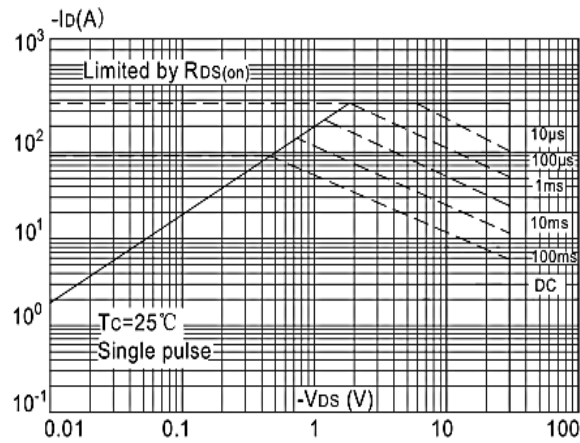

Figure 9: Maximum Safe Operating Area

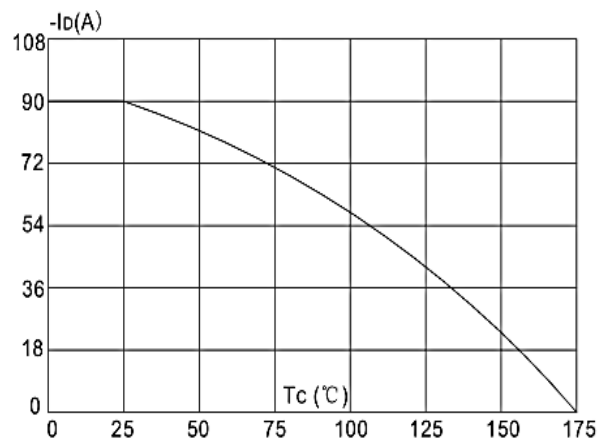

Figure 10: Maximum Continuous Drain Current vs. Case Temperature

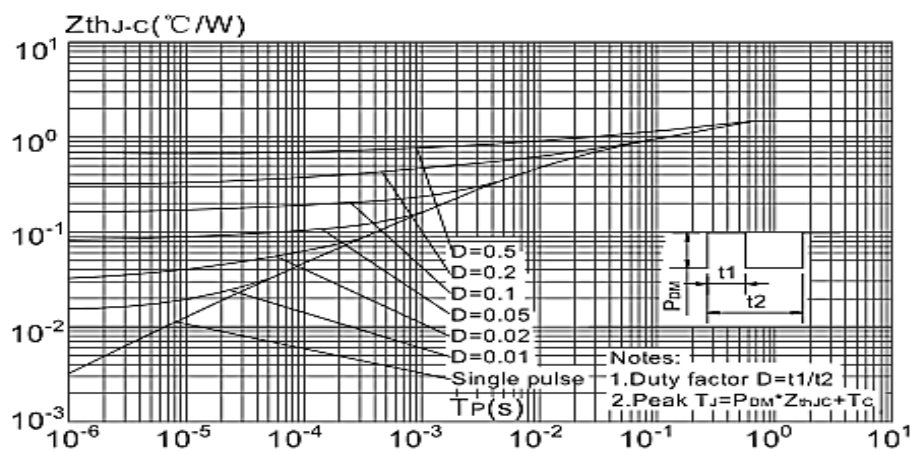
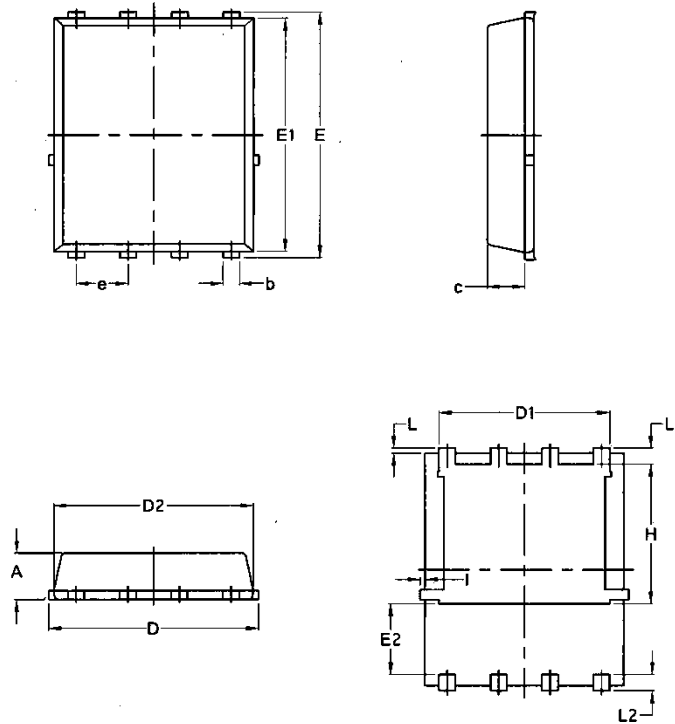

Figure 11: Maximum Effective Transient Thermal Impedance, Junction-to-Case

Package Mechanical Data-DFN5*6-8 -JQ Single



Symbol	Common			
	mm		Inch	
	Mim	Max	Min	Max
A	1.03	1.17	0.0406	0.0461
b	0.34	0.48	0.0134	0.0189
c	0.824	0.0970	0.0324	0.082
D	4.80	5.40	0.1890	0.2126
D1	4.11	4.31	0.1618	0.1697
D2	4.80	5.00	0.1890	0.1969
E	5.95	6.15	0.2343	0.2421
E1	5.65	5.85	0.2224	0.2303
E2	1.60	/	0.0630	/
e	1.27 BSC		0.05 BSC	
L	0.05	0.25	0.0020	0.0098
L1	0.38	0.50	0.0150	0.0197
L2	0.38	0.50	0.0150	0.0197
H	3.30	3.50	0.1299	0.1378
I	/	0.18	/	0.0070