

Description

The LM5D110N10 uses advanced technology to provide excellent $R_{DS(ON)}$, low gate charge and operation with gate voltages as low as 4.5V. This device is suitable for use as a Battery protection or in other Switching application.

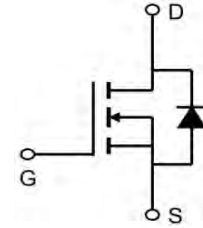

General Features

$V_{DS} = 100V$ $I_D = 110A$

$R_{DS(ON)} < 6m\Omega$ @ $V_{GS} = 10V$ (Typ. 4.2m Ω)

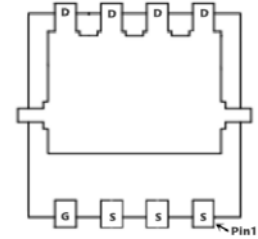
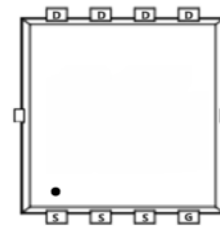

Application

- DC/DC Converter
- LED Backlighting
- Power Management Switches

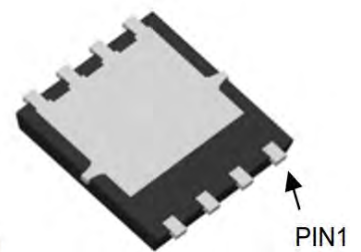
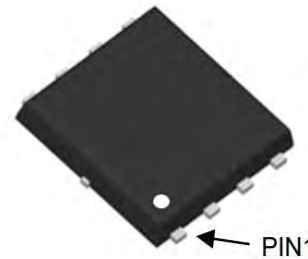

Package Marking and Ordering Information

Device	Device Marking	Device Package	Reel Size	Tape width	Quantity
LM5D110N10	APG110N10NF	DFN5X6-8	-	-	5000 units

Absolute Maximum Ratings ($T_C = 25^\circ C$ unless otherwise noted)

Symbol	Parameter	Value	Unit
V_{DS}	Drain source voltage	100	V
V_{GS}	Gate source voltage	± 20	V
I_D	Continuous drain current, $T_C = 25^\circ C$	110	A
I_{DM}	Pulsed drain current, $T_C = 25^\circ C$	380	A
P_D	Power dissipation, $T_C = 25^\circ C$	113.6	W
E_{AS}	Single pulsed avalanche energy ⁴⁾	205	mJ
T_{stg}, T_j	Operation and storage temperature	-55 to 150	$^\circ C$
$R_{\theta JC}$	Thermal resistance, junction-case	1.1	$^\circ C/W$
$R_{\theta JA}$	Thermal resistance, junction-ambient ⁴⁾	58	$^\circ C/W$

Electrical Characteristics (T_J=25°C, unless otherwise noted)

Symbol	Parameter	Test Conditions	Min.	Typ.	Max.	Unit
VDSS	Drain-Source Breakdown Voltage	V _{GS} = 0V, I _D = 250μA	100	-	-	V
IGSS	Gate-body Leakage current	V _{DS} = 0V, V _{GS} = ±20V	-	-	±100	nA
IDSS	Zero Gate Voltage Drain Current T _J =25°C	V _{DS} =100V, V _{GS} = 0V	-	-	1	μA
IDSS	Zero Gate Voltage Drain Current T _J =100°C		-	-	100	
VGS(th)	Gate-Threshold Voltage	V _{DS} = V _{GS} , I _D = 250μA	1.2	1.8	2.5	V
RDS(on)	Drain-Source on-Resistance ²	V _{GS} = 10V, I _D = 20A	-	4.2	6	mΩ
		V _{GS} = 4.5V, I _D = 15A	-	6.6	9	
Ciss	Input Capacitance	V _{DS} = 50V, V _{GS} = 0V, f = 1MHz	-	4400	-	pF
Coss	Output Capacitance		-	645	-	
Crss	Reverse Transfer Capacitance		-	20	-	
R _g	Gate Resistance	V _{GS} = 0V, V _{DS} = 0V, f = 1MHz	-	1.7	-	Ω
Q _g	Total Gate Charge	V _{GS} = 10V, V _{DS} = 50V, I _D =20A	-	75	-	nC
Q _{gs}	Gate-Source Charge		-	17	-	
Q _{gd}	Gate-Drain Charge		-	13	-	
td(on)	Turn-on Delay Time	V _{GS} = 10V, V _{DS} = 50V, R _G = 3Ω, I _D = 20A	-	15.4	-	ns
t _r	Rise Time		-	13	-	
td(off)	Turn-off Delay Time		-	34	-	
t _f	Fall Time		-	6.2	-	
VSD	Diode Forward Voltage ²	I _F = 20A, V _{GS} = 0V	-	-	1.2	V
I _S	Continuous Source Current ^{1,5}	V _G =V _D =0V, Force Current	-	-	95	A
trr	Body Diode Reverse Recovery Time	I _F = 20A, dI/dt=100A/μs	-	55	-	ns
Q _{rr}	Body Diode Reverse Recovery Charge		-	101	-	nC

Notes:

- 1、 The data tested by surface mounted on a 1 inch² FR-4 board with 2OZ copper.
- 2、 The data tested by pulsed , pulse width ≤ 300us , duty cycle ≤ 2%
- 3、 The EAS data shows Max. rating . The test condition is V_{DD}=50V, V_{GS}=10V, L=0.4mH, I_{AS}=32A
- 4、 The power dissipation is limited by 150°C junction temperature
- 5、 The data is theoretically the same as I_D and I_{DM} , in real applications , should be limited by total power dissipation.

Typical Electrical and Thermal Characteristics

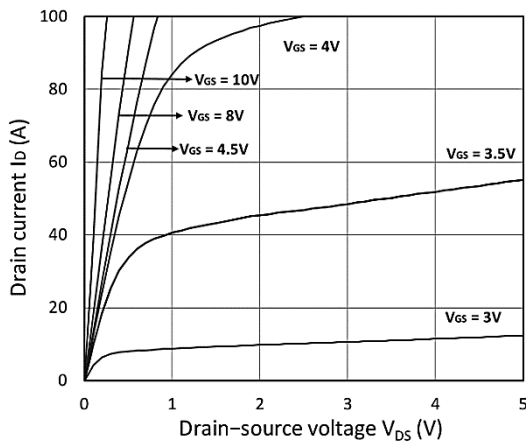

Figure 1. Output Characteristics

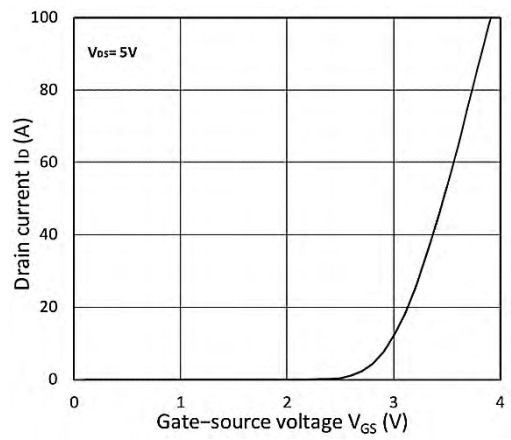

Figure 2. Transfer Characteristics

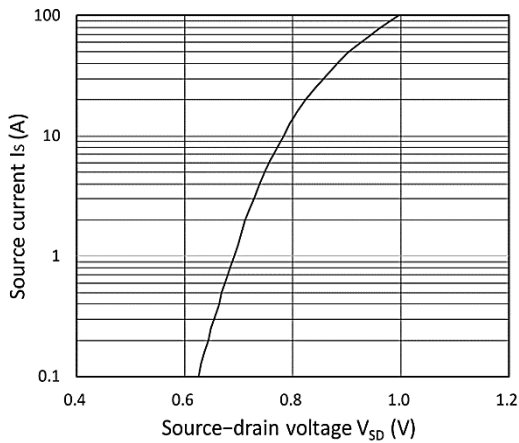

Figure 3. Forward Characteristics of Reverse

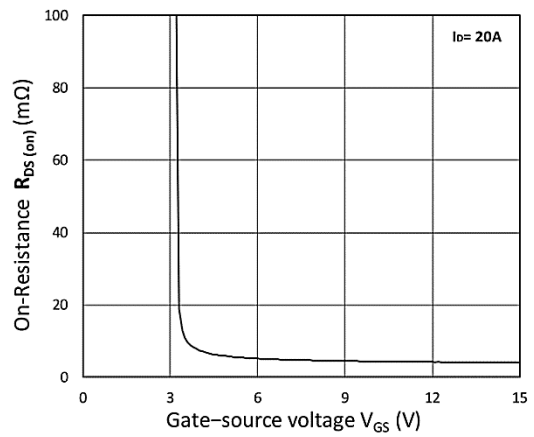

Figure 4. $R_{DS(ON)}$ vs. V_{GS}

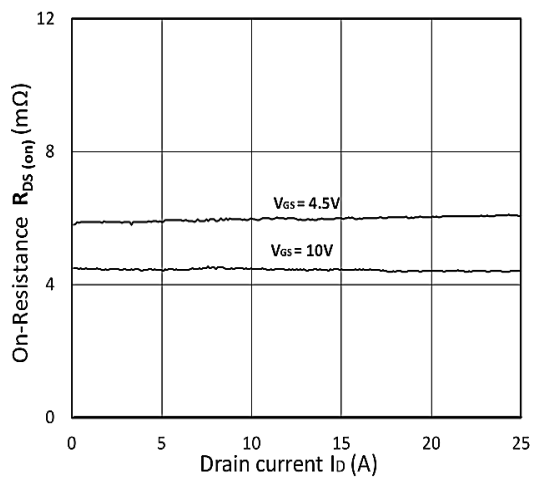

Figure 5. $R_{DS(ON)}$ vs. I_D

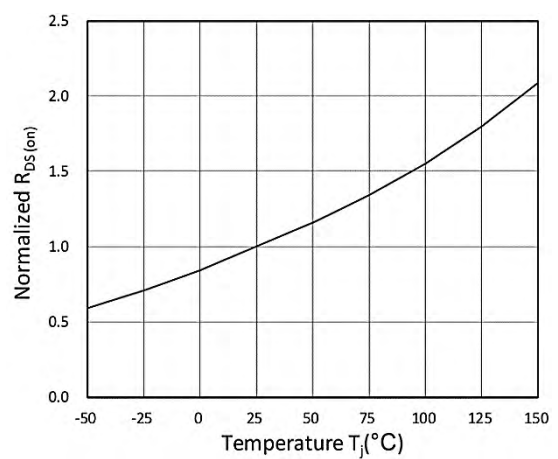

Figure 6. Normalized $R_{DS(on)}$ vs. Temperature

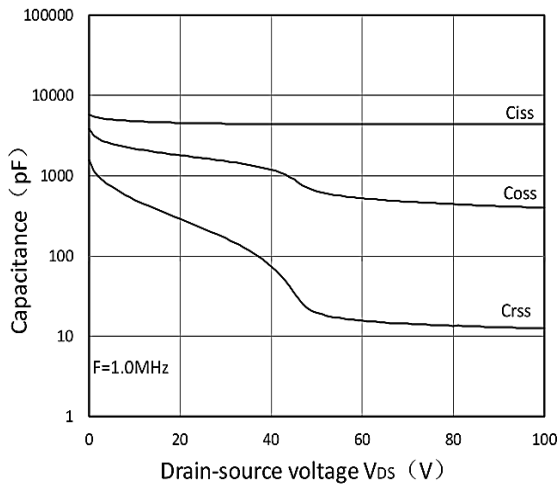

Figure 7. Capacitance Characteristics

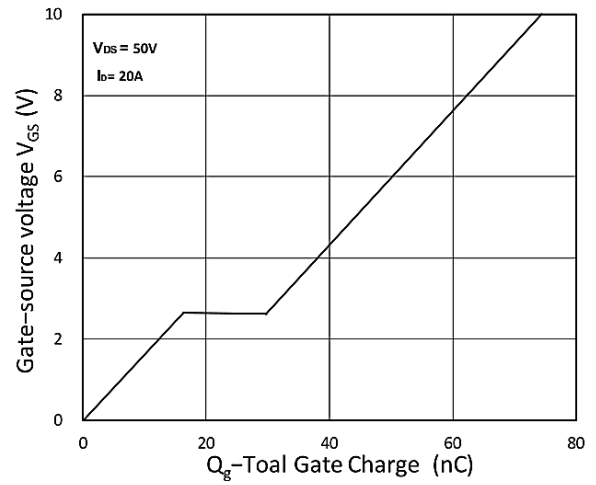

Figure 8. Gate Charge Characteristics

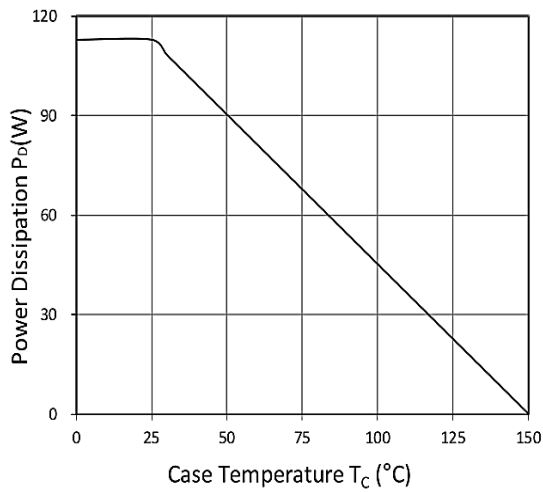

Figure 9. Power Dissipation

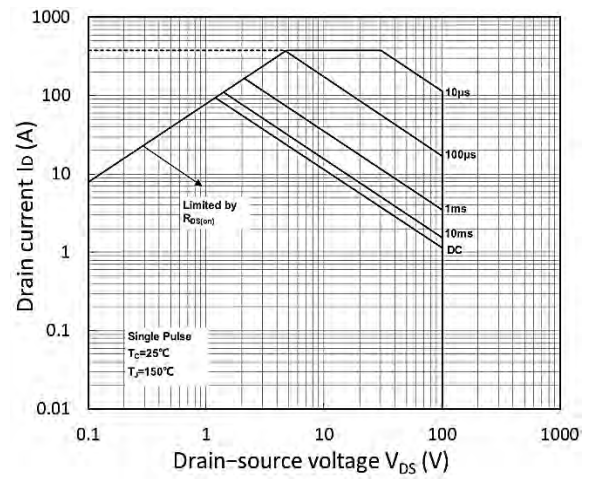

Figure 10. Safe Operating Area

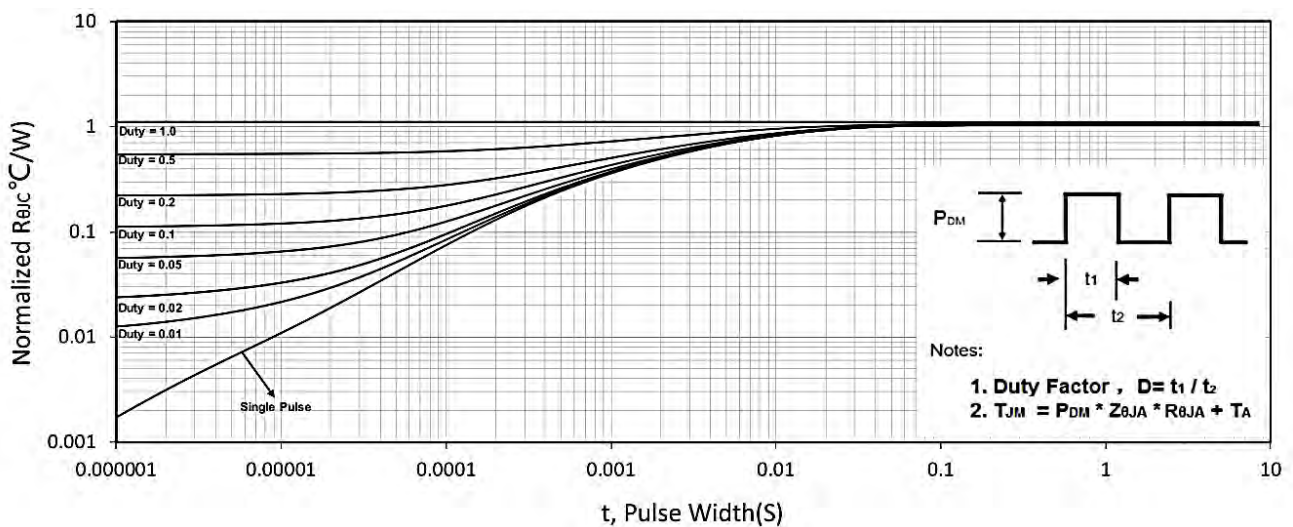
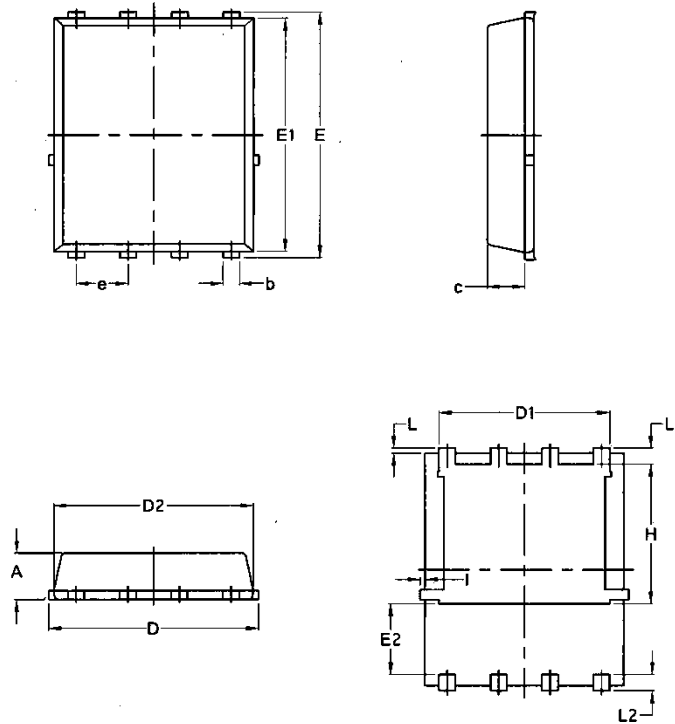

Figure 11. Normalized Maximum Transient Thermal Impedance

Package Mechanical Data-DFN5*6-8-JQ Single



Symbol	Common			
	mm		Inch	
	Min	Max	Min	Max
A	1.03	1.17	0.0406	0.0461
b	0.34	0.48	0.0134	0.0189
c	0.824	0.0970	0.0324	0.082
D	4.80	5.40	0.1890	0.2126
D1	4.11	4.31	0.1618	0.1697
D2	4.80	5.00	0.1890	0.1969
E	5.95	6.15	0.2343	0.2421
E1	5.65	5.85	0.2224	0.2303
E2	1.60	/	0.0630	/
e	1.27 BSC		0.05 BSC	
L	0.05	0.25	0.0020	0.0098
L1	0.38	0.50	0.0150	0.0197
L2	0.38	0.50	0.0150	0.0197
H	3.30	3.50	0.1299	0.1378
I	/	0.18	/	0.0070