

General Description

The LM1503 uses advanced trench technology and design to provide excellent $R_{DS(ON)}$ with low gate charge. This device is suitable for use in PWM, load switching and general purpose applications.

Features

V_{DS}	30V
I_D (at $V_{GS}=10V$)	13A
$R_{DS(ON)}$ (at $V_{GS}=10V$)	15m Ω (Max)
$R_{DS(ON)}$ (at $V_{GS}=4.5V$)	20m Ω (Max)

SOP8

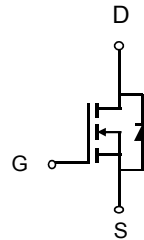
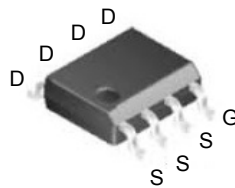

Absolute Maximum Ratings $T_A=25^\circ\text{C}$ unless otherwise noted

Parameter	Symbol	Maximum	Units	
Drain-Source Voltage	V_{DS}	30	V	
Gate-Source Voltage	V_{GS}	± 20	V	
Drain Current-Continuous	TC=25 $^\circ\text{C}$	I_D	13	A
	TC=100 $^\circ\text{C}$	I_D	8.5	A
Drain Current – Pulsed	I_{DM}	52	A	
Maximum Power Dissipation	P_D	2.1	W	
Junction and Storage Temperature Range	T_J, T_{STG}	-55 To 150	$^\circ\text{C}$	

Thermal Characteristics

Parameter	Symbol	Typ	Max	Unit
Thermal Resistance junction-case	$R_{\theta Jc}$		7	$^\circ\text{C}/\text{W}$
Thermal Resistance unction-to-Ambient	$R_{\theta JA}$		62	$^\circ\text{C}/\text{W}$

Electrical Characteristics (T_J=25°C unless otherwise noted)

Symbol	Parameter	Condition	Min	Typ	Max	Unit
STATIC PARAMETERS						
BV_{DSS}	Drain-Source Breakdown Voltage	$V_{GS}=0V, I_D=250\mu A$	30			V
I_{DSS}	Zero Gate Voltage Drain Current	$V_{DS}=30V, V_{GS}=0V$			1	μA
I_{GSS}	Gate-Body Leakage Current	$V_{GS}=\pm 20V, V_{DS}=0V$			± 100	nA
$V_{GS(th)}$	Gate Threshold Voltage	$V_{DS}=V_{GS}, I_D=250\mu A$	0.6	1.0	1.5	V
$R_{DS(ON)}$	Drain-Source On-State Resistance	$V_{GS}=10V, I_D=10A$		12	15	m Ω
		$V_{GS}=4.5V, I_D=5A$		14	20	m Ω
DYNAMIC PARAMETERS						
C_{ISS}	Input Capacitance	$V_{DS}=15V, V_{GS}=0V,$ $F=1.0MHz$		620		pF
C_{OSS}	Output Capacitance			85		pF
C_{RSS}	Reverse Transfer Capacitance			60		pF
SWITCHING PARAMETERS						
$t_{d(on)}$	Turn-on Delay Time	$V_{GS}=10V$ $V_{DS}=15V$ $R_L=2.6\Omega$ $R_{GEN}=3\Omega$		2.6		nS
t_r	Turn-on Rise Time			8.5		nS
$t_{d(off)}$	Turn-Off Delay Time			18		nS
t_f	Turn-Off Fall Time			5		nS
Q_g	Total Gate Charge	$V_{DS}=15V, I_D=3A,$ $V_{GS}=4.5V$		7.1		nC
Q_{gs}	Gate-Source Charge			1.4		nC
Q_{gd}	Gate-Drain Charge			1.5		nC
V_{SD}	Diode Forward Voltage	$V_{GS}=0V, I_{SD}=1A$		0.72	1.3	V
R_g	Gate resistance	$V_{GS}=0V, V_{DS}=0V,$ $F=1MHz$		2		Ω

Note:

1. Repetitive Rating : Pulsed width limited by maximum junction temperature.
2. The data tested by pulsed , pulse width $\leq 300\mu s$, duty cycle $\leq 2\%$.
3. Essentially independent of operating temperature.

TYPICAL ELECTRICAL AND THERMAL CHARACTERISTICS

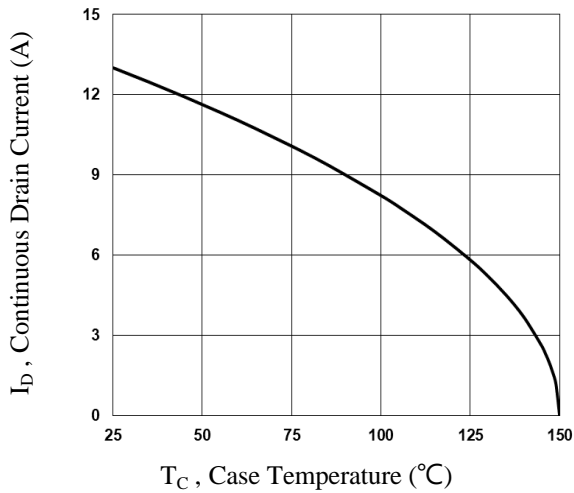

Fig.1 Continuous Drain Current vs. T_C

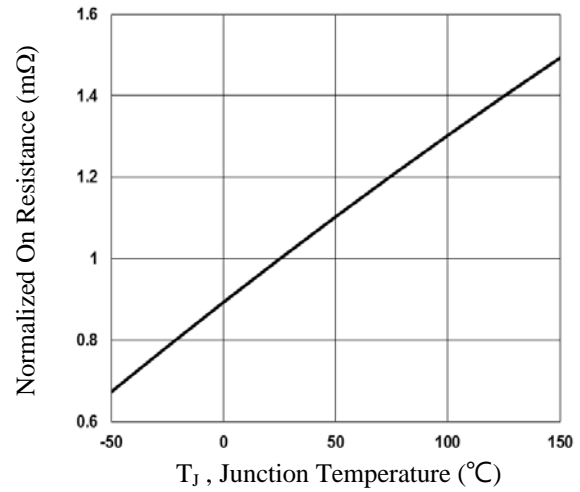

Fig.2 Normalized $R_{DS(on)}$ vs. T_J

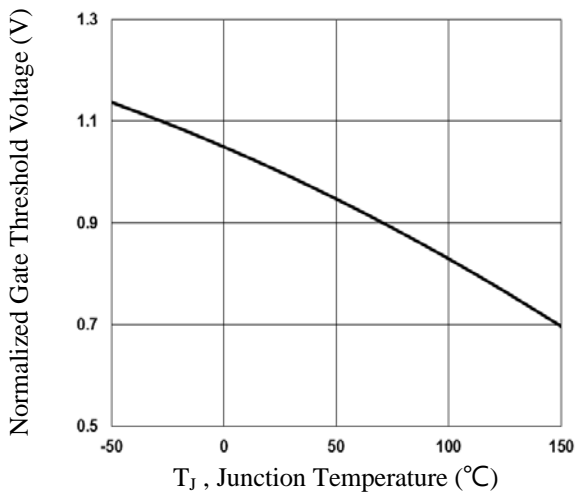

Fig.3 Normalized V_{th} vs. T_J

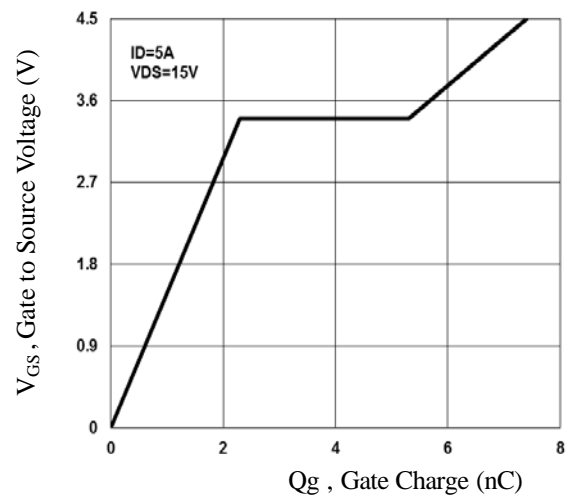

Fig.4 Gate Charge Waveform

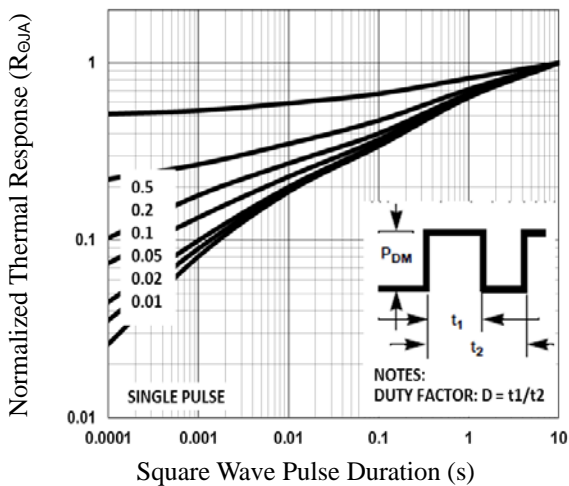

Fig.5 Normalized Transient Response

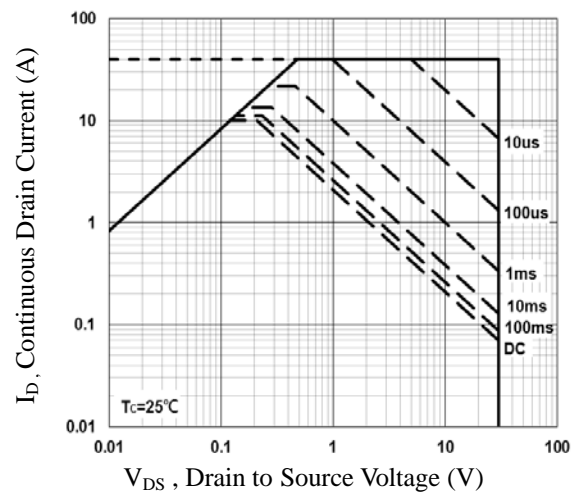

Fig.6 Maximum Safe Operation Area

TYPICAL ELECTRICAL AND THERMAL CHARACTERISTICS

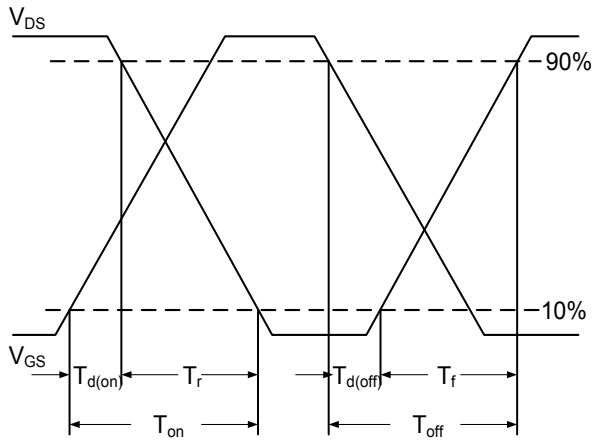

Fig.7 Switching Time Waveform

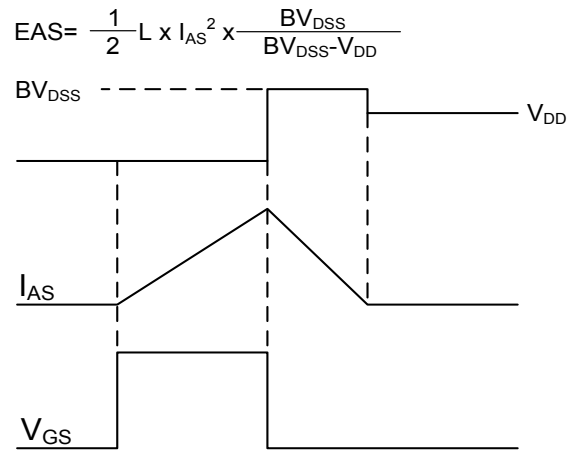
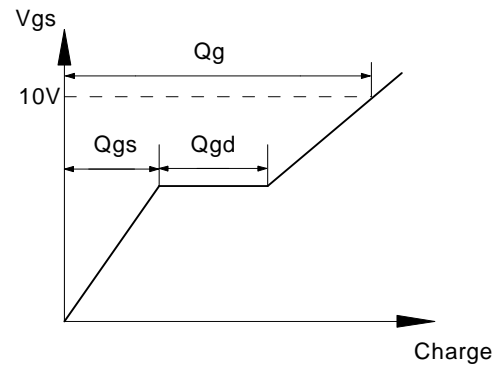
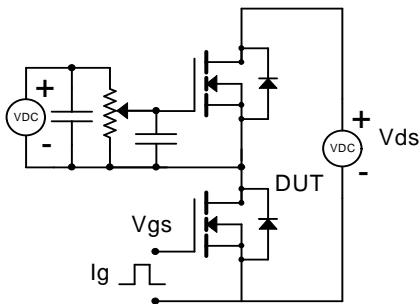
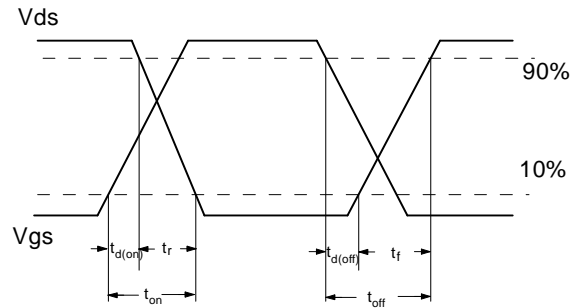
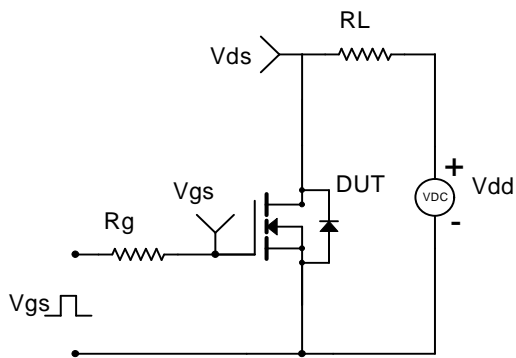

Fig.8 EAS Waveform

Gate Charge Test Circuit & Waveform



Resistive Switching Test Circuit & Waveforms



Unclamped Inductive Switching (UIS) Test Circuit & Waveforms

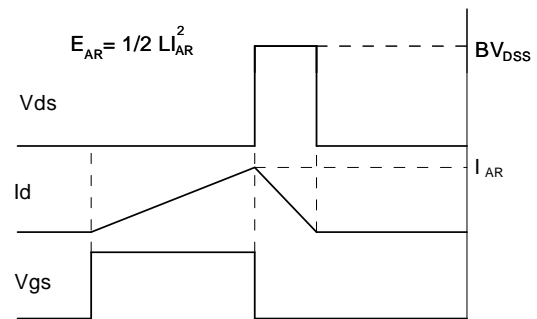
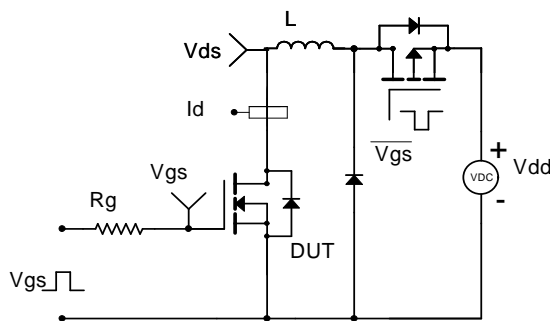

Diode Recovery Test Circuit & Waveforms

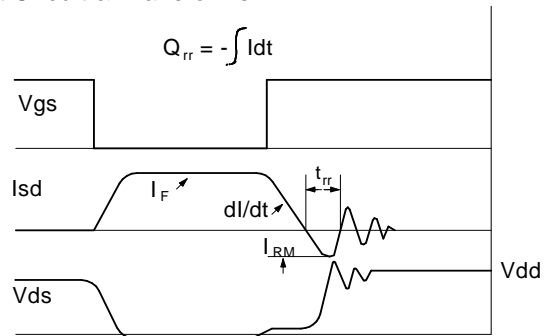
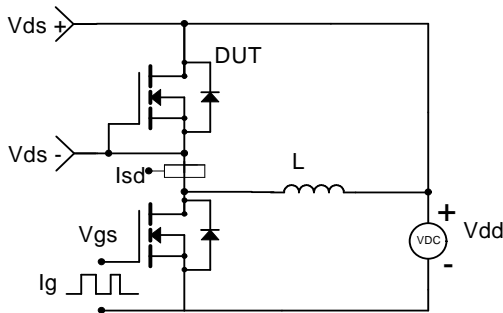

SOP8 PACKAGE INFORMATION

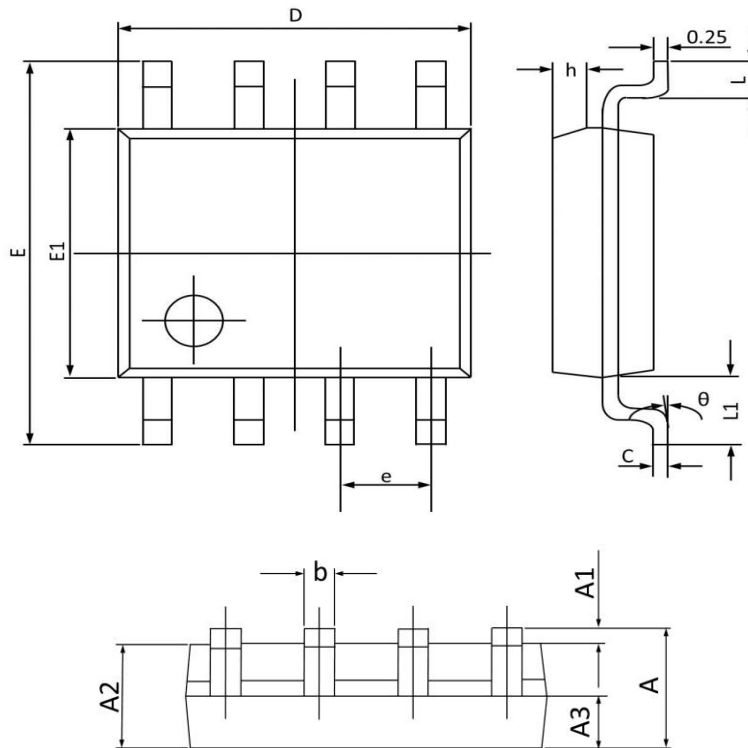

Symbol	Dimensions In Millimeters		Dimensions In Inches	
	Min	Max	Min	Max
A	1.350	1.750	0.053	0.068
A1	0.100	0.250	0.004	0.009
A2	1.300	1.500	0.052	0.059
A3	0.600	0.700	0.024	0.027
b	0.390	0.480	0.016	0.018
c	0.210	0.260	0.009	0.010
D	4.700	5.100	0.186	0.200
E	5.800	6.200	0.229	0.244
E1	3.700	4.100	0.146	0.161
e	1.270(BSC)		0.050(BSC)	
h	0.250	0.500	0.010	0.019
L	0.500	0.800	0.019	0.031
L1	1.050(BSC)		0.041(BSC)	
θ	0°	8°	0°	8°