

## N-Channel Enhancement Mode Power MOSFET

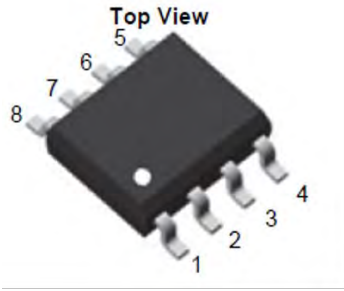

**SOP-8**

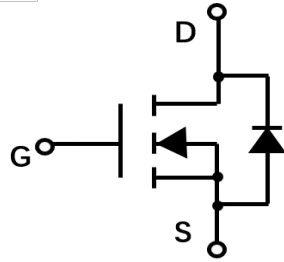
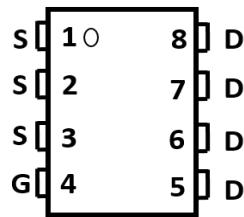

### Product Summary

- $V_{DS}$  100V
- $I_D$  15A
- $R_{DS(ON)}$  (at  $V_{GS}=10V$ ) < 9.5 mohm
- $R_{DS(ON)}$  (at  $V_{GS}=4.5V$ ) < 12.5 mohm

### General Description

- Split Gate Trench MOSFET technology
- Excellent package for heat dissipation
- High density cell design for low  $R_{DS(ON)}$

### Applications

- DC/DC Primary Side Switch
- Telecom/Server
- Synchronous Rectification

### ■ Absolute Maximum Ratings ( $T_A=25^\circ\text{C}$ unless otherwise noted)

Parameter		Symbol	Maximum	Unit
Drain-source Voltage		$V_{DS}$	100	V
Gate-source Voltage		$V_{GS}$	$\pm 20$	V
Drain Current	$T_A=25^\circ\text{C}$	$I_D$	15	A
	$T_A=100^\circ\text{C}$		9.5	
Pulsed Drain Current <sup>A</sup>		$I_{DM}$	75	A
Avalanche Energy, Single Pulse(L=0.5mH)		$E_{AS}$	200	mJ
Total Power Dissipation <sup>B</sup>		$P_D$	3.8	W
Junction and Storage Temperature Range		$T_J, T_{STG}$	-55~+150	$^\circ\text{C}$

### ■ Thermal resistance

Parameter		Symbol	Typ	Max	Units
Thermal Resistance Junction-to-Ambient <sup>C</sup>	$t \leq 10S$	$R_{\theta JA}$	25	32	$^\circ\text{C/W}$
Thermal Resistance Junction-to-Ambient <sup>C</sup>	Steady-State		47	60	
Thermal Resistance Junction-to-Lead	Steady-State	$R_{\theta JL}$	13	20	

### ■ Ordering Information (Example)

PREFERRED P/N	PACKING CODE	Marking	MINIMUM PACKAGE(pcs)	INNER BOX QUANTITY(pcs)	OUTER CARTON QUANTITY(pcs)	DELIVERY MODE
LMS15G10A	F2	Q15G10A	4000			13" reel

## ■ Electrical Characteristics (T<sub>J</sub>=25°C unless otherwise noted)

Parameter	Symbol	Conditions	Min	Typ	Max	Units
<b>Static Parameter</b>						
Drain-Source Breakdown Voltage	BV <sub>DSS</sub>	V <sub>GS</sub> = 0V, I <sub>D</sub> =250μA	100			V
Zero Gate Voltage Drain Current	I <sub>DSS</sub>	V <sub>DS</sub> =100V, V <sub>GS</sub> =0V, T <sub>J</sub> =25°C			1	μA
Gate-Body Leakage Current	I <sub>GSS</sub>	V <sub>GS</sub> = ±20V, V <sub>DS</sub> =0V			±100	nA
Gate Threshold Voltage	V <sub>GS(th)</sub>	V <sub>DS</sub> = V <sub>GS</sub> , I <sub>D</sub> =250μA	1.0	1.8	3.0	V
Static Drain-Source On-Resistance	R <sub>DS(on)</sub>	V <sub>GS</sub> =10V, I <sub>D</sub> =10A		8.0	9.5	mΩ
	R <sub>DS(on)</sub>	V <sub>GS</sub> =4.5V, I <sub>D</sub> =5A		9.7	12.5	mΩ
Diode Forward Voltage	V <sub>SD</sub>	I <sub>S</sub> =15A, V <sub>GS</sub> =0V			1.3	V
Maximum Body-Diode Continuous Current	I <sub>S</sub>				15	A
Gate resistance	R <sub>G</sub>	f=1MHz, Open drain		0.68		Ω
<b>Dynamic Parameters</b>						
Input Capacitance	C <sub>iss</sub>	V <sub>DS</sub> =50V, V <sub>GS</sub> =0V, f=1MHZ		2270		pF
Output Capacitance	C <sub>oss</sub>			797		
Reverse Transfer Capacitance	C <sub>rss</sub>			36		
<b>Switching Parameters</b>						
Total Gate Charge	Q <sub>g</sub>	V <sub>GS</sub> =10V, V <sub>DS</sub> =50V, I <sub>D</sub> =10A		32		nC
Gate-Source Charge	Q <sub>gs</sub>			11.1		
Gate-Drain Charge	Q <sub>gd</sub>			4.78		
Reverse Recovery Charge	Q <sub>rr</sub>	I <sub>F</sub> =10A, di/dt=100A/us		84		
Reverse Recovery Time	t <sub>rr</sub>			51.5		
Turn-on Delay Time	t <sub>D(on)</sub>	V <sub>GS</sub> =10V, V <sub>DD</sub> =50V, I <sub>D</sub> =10A R <sub>GEN</sub> =2.2Ω		51		ns
Turn-on Rise Time	t <sub>r</sub>			14.4		
Turn-off Delay Time	t <sub>D(off)</sub>			69.2		
Turn-off fall Time	t <sub>f</sub>			20.6		

A. Repetitive rating; pulse width limited by max. junction temperature.

B. Pd is based on max. junction temperature, using ≤10s junction-ambient thermal resistance.

C. The value of R<sub>θJA</sub> is measured with the device mounted on 1in<sup>2</sup> FR-4 board with 2oz. Copper, in a still air environment with T<sub>A</sub> =25°C. The value in any given application depends on the user's specific board design.

## ■ Typical Performance Characteristics

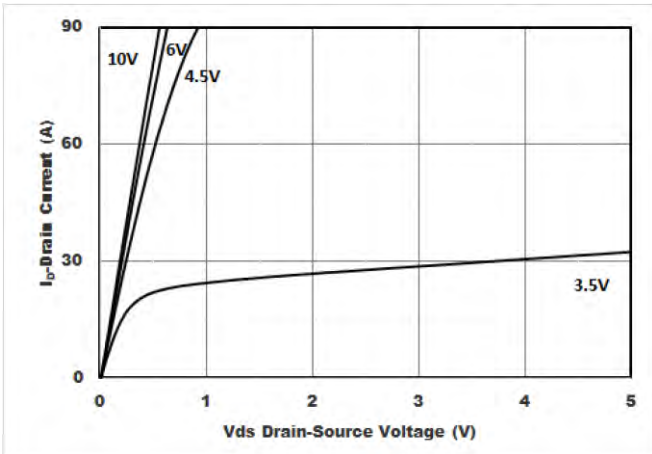

Figure1. Output Characteristics

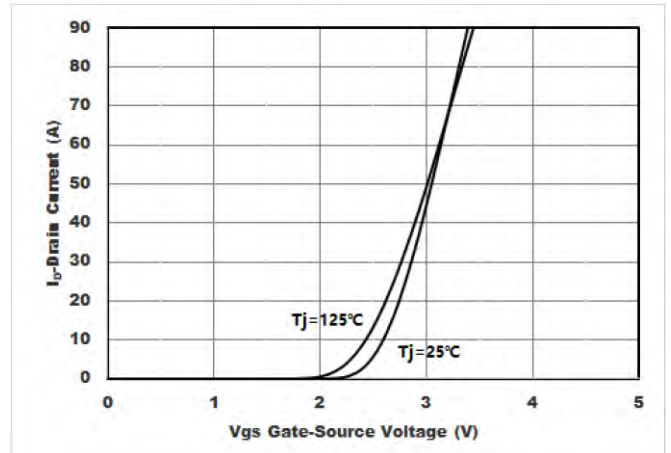

Figure2. Transfer Characteristics

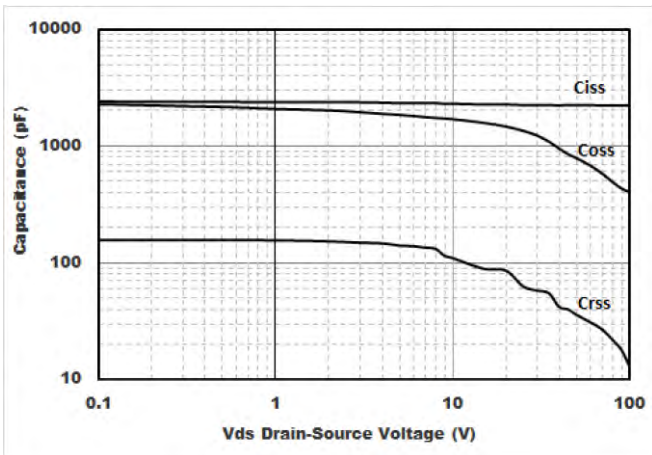

Figure3. Capacitance Characteristics

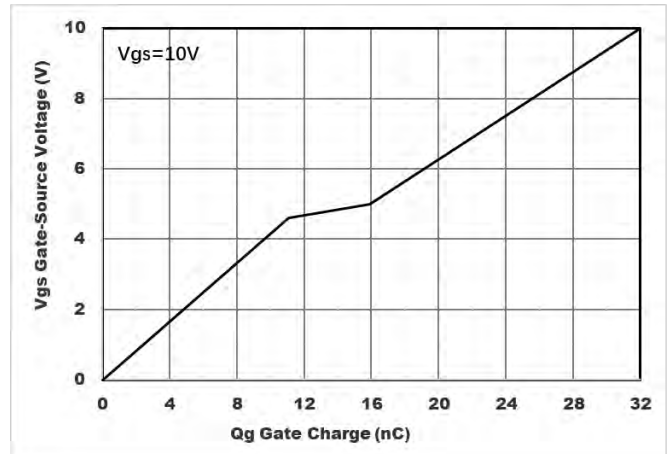

Figure4. Gate Charge

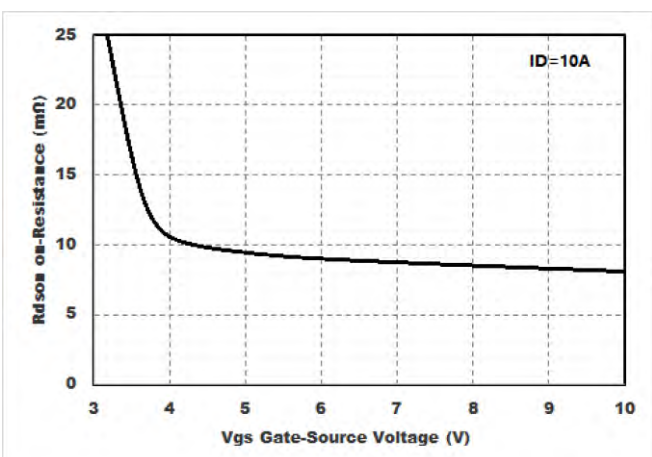

Figure5. Drain-Source on Resistance

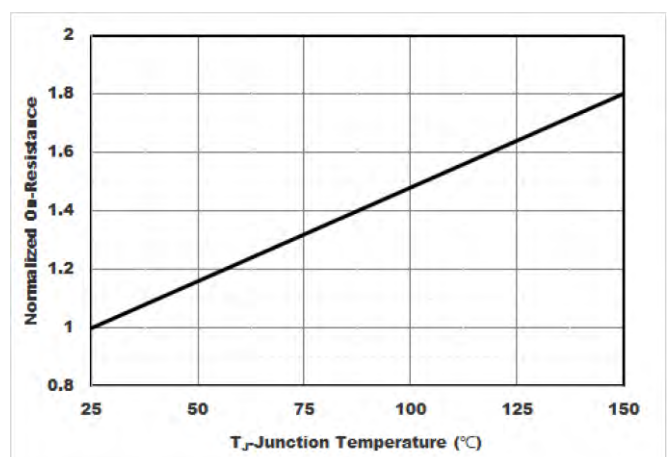

Figure6. Drain Current

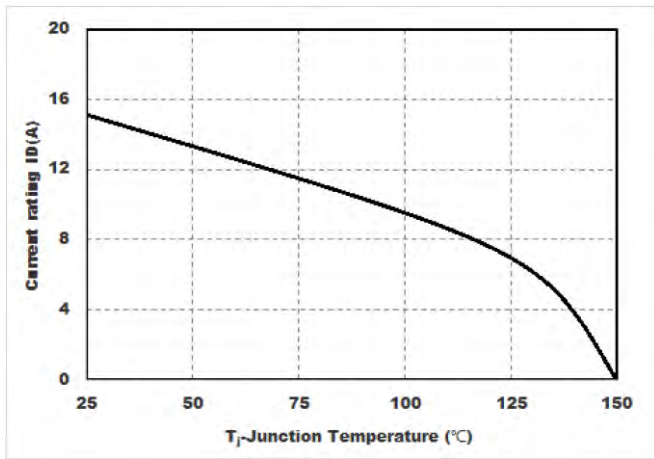

Figure7. Drain current

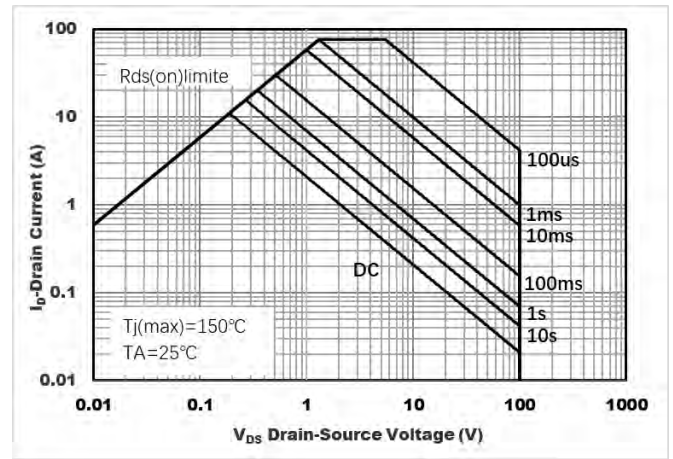

Figure8. Safe Operation Area

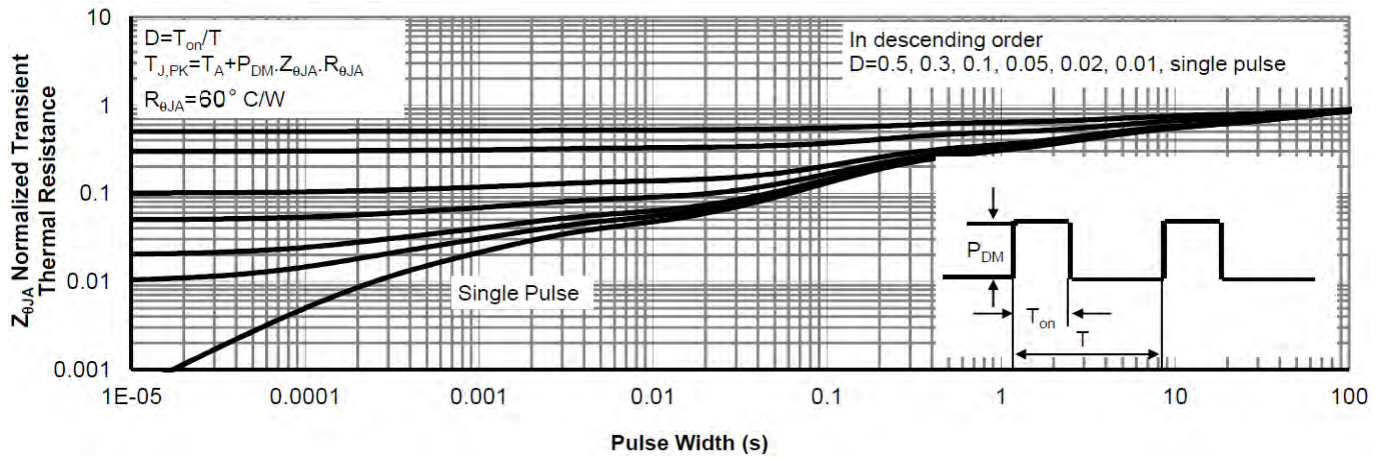
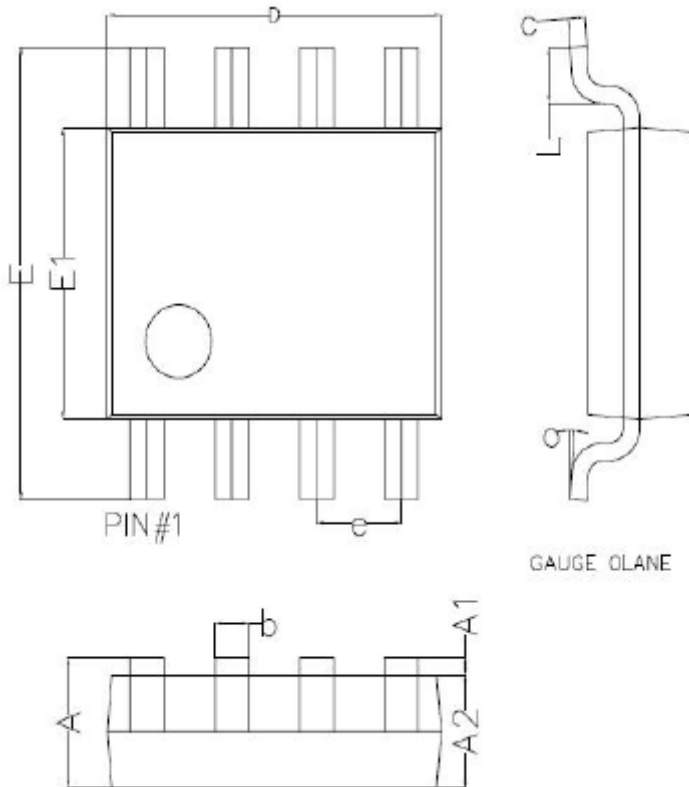

Figure9. Normalized Maximum Transient Thermal Impedance

## ■ SOP-8 Package information



Symbol	Dim in mm		
	Min	Nor	Max
A	1.35	1.55	1.75
A1	0.02	0.065	0.10
A2	1.35	1.45	1.55
b	0.33	0.42	0.51
c	0.17	0.21	0.25
D	4.80	4.90	5.00
e	1.270 (BSC)		
E	5.80	6.00	6.20
E1	3.80	3.90	4.00
L	0.4	0.835	1.27
θ	0°	4°	8°