

Description

The LM8S12P03 uses advanced trench technology to provide excellent $R_{DS(ON)}$, low gate charge and operation with gate voltages as low as 4.5V. This device is suitable for use as a Battery protection or in other Switching application.

Dimensions SOP-8

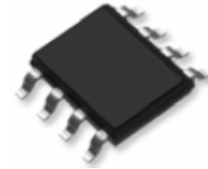

General Features

- $V_{DS} = -30V$ $I_D = -11.3A$
- $R_{DS(ON)} < 16m\Omega$ @ $V_{GS} = -10V$

Application

- Lithium battery protection
- Wireless impact
- Mobile phone fast charging

Pin Configuration

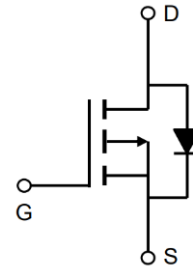

Package Marking and Ordering Information

Device	Device Marking	Device Package	Reel Size	Tape width	Quantity
LM8S12P03	AP4407B	SOP-8	Ø330mm	12mm	3000 units

Absolute Maximum Ratings (TC=25°C unless otherwise noted)

Symbol	Parameter	Rating	Units
V _{DS}	Drain-Source Voltage	-30	V
V _{GS}	Gate-Source Voltage	±20	V
I _D @T _A =25°C	Continuous Drain Current, V _{GS} @ -10V ¹	-11.3	A
I _D @T _A =70°C	Continuous Drain Current, V _{GS} @ -10V ¹	-8.6	A
IDM	Pulsed Drain Current ²	-50	A
EAS	Single Pulse Avalanche Energy ³	72.2	mJ
IAS	Avalanche Current	-38	A
P _D @T _A =25°C	Total Power Dissipation ⁴	3.1	W
P _D @T _A =70°C	Total Power Dissipation ⁴	2	W
TSTG	Storage Temperature Range	-55 to 150	°C
T _J	Operating Junction Temperature Range	-55 to 150	°C
R _{θJA}	Thermal Resistance Junction-Ambient ¹	75	°C/W
R _{θJA}	Thermal Resistance Junction-Ambient ¹ (t ≦ 10s)	40	°C/W
R _{θJC}	Thermal Resistance Junction-Case ¹	24	°C/W

Electrical Characteristics (T_J=25°C, unless otherwise noted)

Symbol	Parameter	Test Condition	Min.	Typ.	Max.	Units
V(BR)DSS	Drain-Source Breakdown Voltage	V _{GS} =0V, I _D = -250μA	-30	-33	-	V
IDSS	Zero Gate Voltage Drain Current	V _{DS} = -30V, V _{GS} =0V,	-	-	-1	μA
IGSS	Gate to Body Leakage Current	V _{DS} =0V, V _{GS} = ±20V	-	-	±100	nA
VGS(th)	Gate Threshold Voltage	V _{DS} =V _{GS} , I _D = -250μA	-1.0	-1.5	-2.5	V
RDS(on)	Static Drain-Source on-Resistance note3	V _{GS} = -10V, I _D = -10A	-	11.5	16	mΩ
		V _{GS} = -4.5V, I _D = -5A	-	16	25	
C _{iss}	Input Capacitance	V _{DS} = -15V, V _{GS} =0V, f=1.0MHZ	-	2130	-	pF
C _{oss}	Output Capacitance		-	280	-	pF
C _{rss}	Reverse Transfer Capacitance		-	252	-	pF
Q _g	Total Gate Charge	V _{DS} = -15V, I _D = -5A, V _{GS} = -10V	-	22	-	nC
Q _{gs}	Gate-Source Charge		-	4	-	nC
Q _{gd}	Gate-Drain("Miller") Charge		-	5.8	-	nC
td(on)	Turn-on Delay Time	V _{DD} = -15V, I _D = -10A, V _{GS} = -10V, R _{GEN} =2.5Ω	-	9	-	ns
t _r	Turn-on Rise Time		-	13	-	ns
td(off)	Turn-off Delay Time		-	48	-	ns
t _f	Turn-off Fall Time		-	20	-	ns
IS	Maximum Continuous Drain to Source Diode Forward Current		-	-	-11	A
ISM	Maximum Pulsed Drain to Source Diode Forward Current		-	-	-44	A
VSD	Drain to Source Diode Forward Voltage	V _{GS} =0V, I _S = -11A	-	-0.8	-1.2	V

Note :

- 1、 The data tested by surface mounted on a 1 inch 2 FR-4 board with 2OZ copper.
- 2、 The data tested by pulsed , pulse width ≅ 300us , duty cycle ≅ 2%
- 3、 The EAS data shows Max. rating . The test condition is V_{DD}=-25V,V_{GS}=-10V,L=0.1mH,I_{AS}=-8A
- 4、 The power dissipation is limited by 150°C junction temperature
- 5、 The data is theoretically the same as ID and IDM , in real applications , should be limited by total power dissipation.

Typical Electrical and Thermal Characteristics

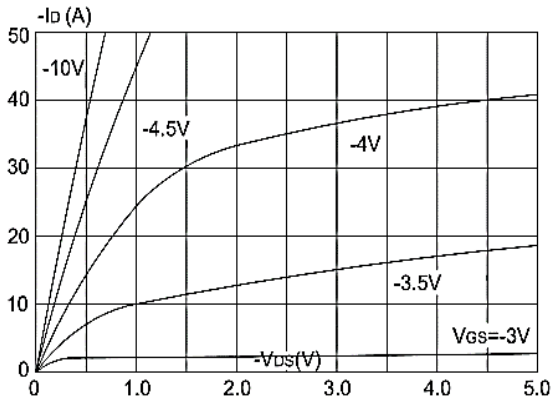

Figure 1: Output Characteristics

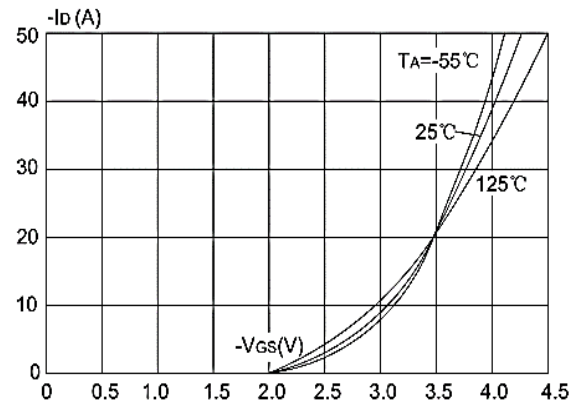

Figure 2: Typical Transfer Characteristics

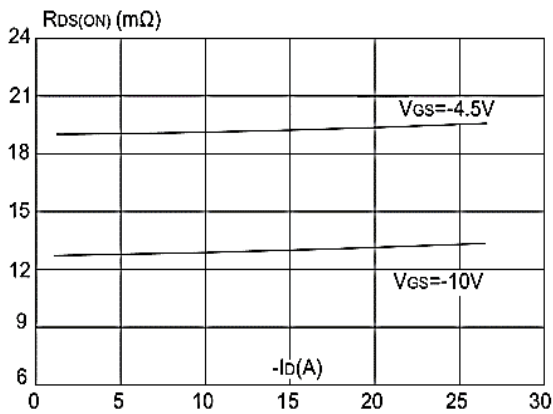

Figure 3: On-resistance vs. Drain Current

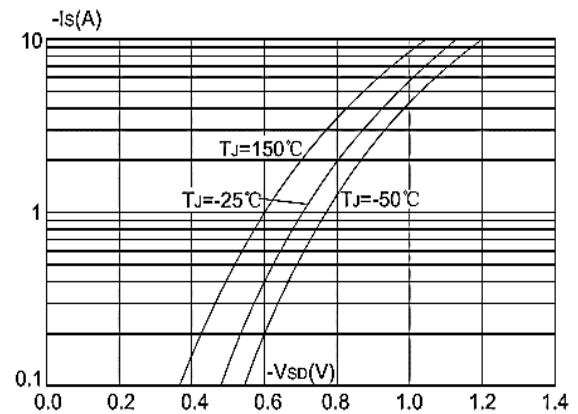

Figure 4: Body Diode Characteristics

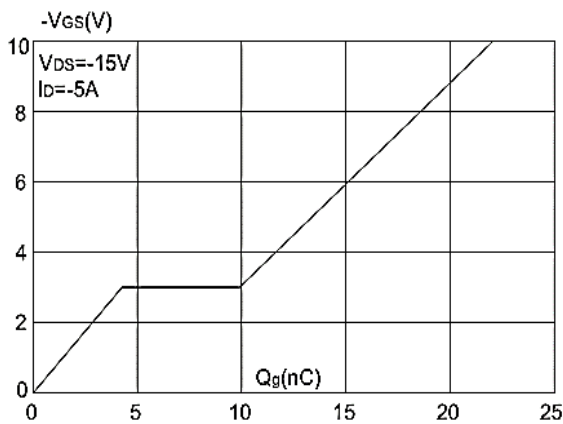

Figure 5: Gate Charge Characteristics

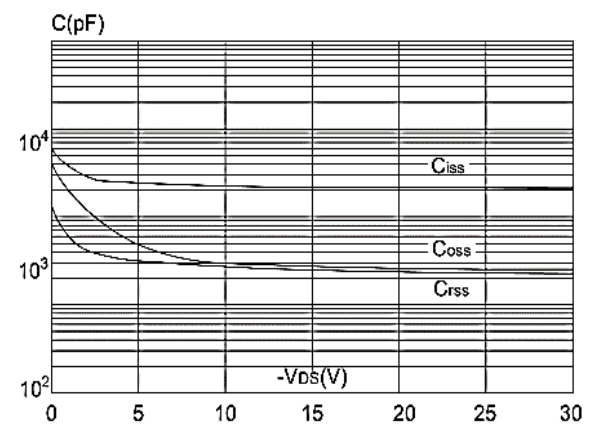

Figure 6: Capacitance Characteristics

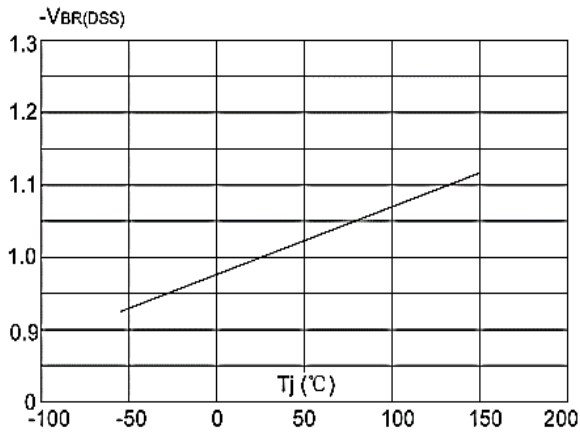

Figure 7: Normalized Breakdown Voltage vs. Junction Temperature

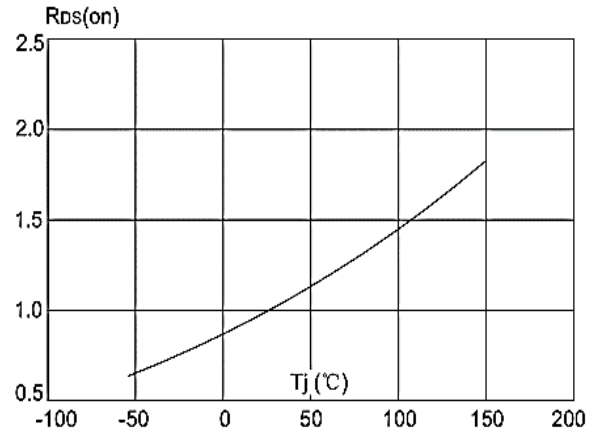

Figure 8: Normalized on Resistance vs. Junction Temperature

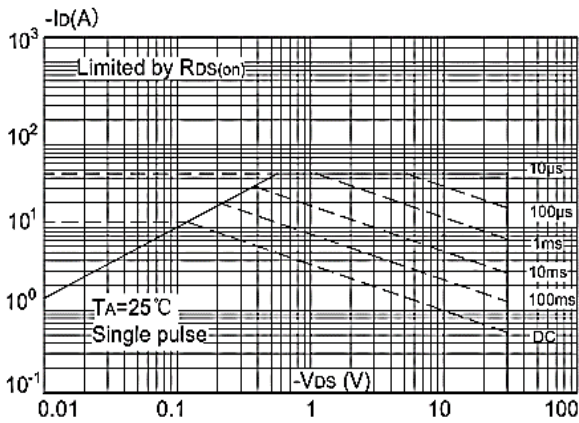

Figure 9: Maximum Safe Operating Area

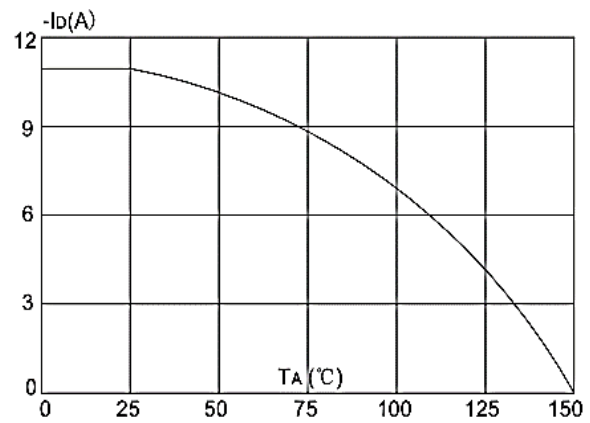

Figure 10: Maximum Continuous Drain Current vs. Ambient Temperature

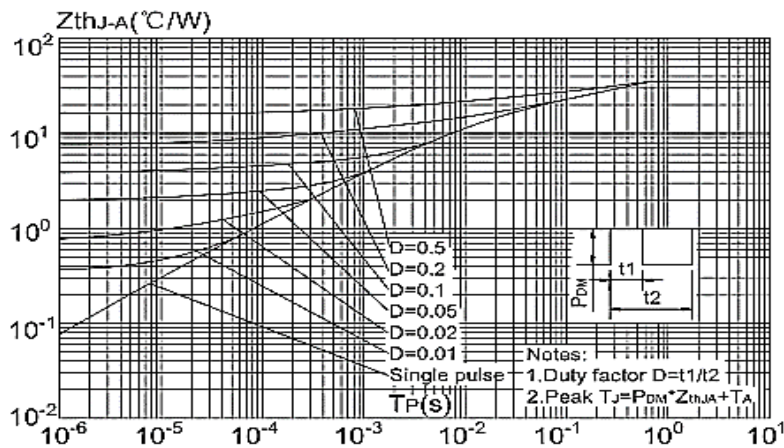
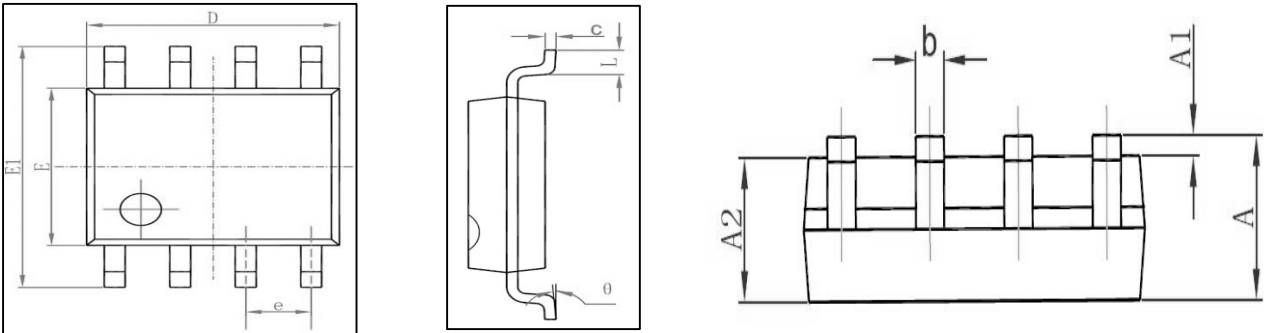
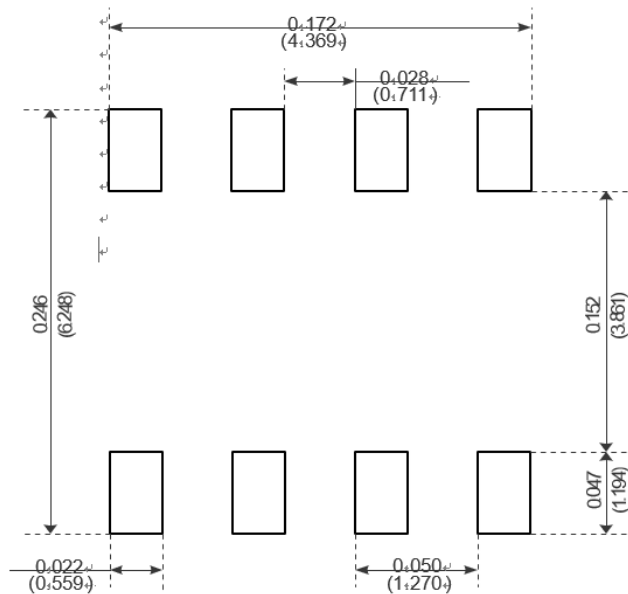

Figure.11: Maximum Effective Transient Thermal Impedance, Junction-to-Ambient

Package Mechanical Data-SOP-8



Symbol	Dimensions In Millimeters		Dimensions In Inches	
	Min	Max	Min	Max
A	1.350	1.750	0.053	0.069
A1	0.100	0.250	0.004	0.010
A2	1.350	1.550	0.053	0.061
b	0.330	0.510	0.013	0.020
c	0.170	0.250	0.006	0.010
D	4.700	5.100	0.185	0.200
E	3.800	4.000	0.150	0.157
E1	5.800	6.200	0.228	0.244
e	1.270 (BSC)		0.050 (BSC)	
L	0.400	1.270	0.016	0.050
θ	0°	8°	0°	8°



Recommended Minimum Pads

Shanghai Leiditech Electronic Co.,Ltd
 Email: sale1@leiditech.com
 Tel : +86- 021 50828806
 Fax : +86- 021 50477059